



ACF

VENTILATOREN



***Radialventilator
Baureihe: RM***

RM

VENTILATORE AD ALTO RENDIMENTO
HIGH EFFICIENCY FAN



GIRANTE A PALE CURVE ROVESCE
BACKWARD CURVED BLADES IMPELLER

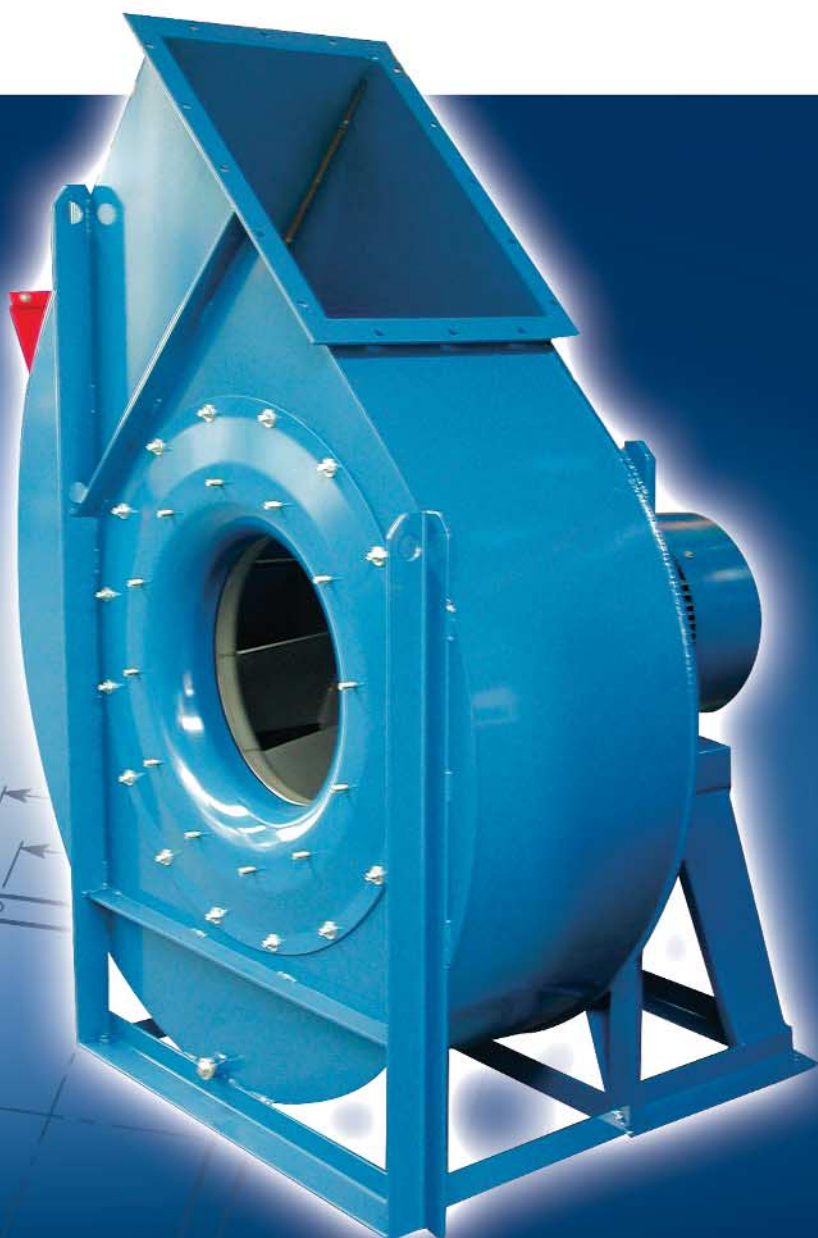

MEDIA PRESSIONE
MEDIUM PRESSURE

Portata/Flow rate:
360 ÷ 120000 m³/h

Pressione/Pressure:
40 ÷ 590 mm H₂O



ACF



Ihr Partner für Ventilatoren
Stahl | Edelstahl | Aluminium Kunststoff

RM

VENTILATORE AD ALTO RENDIMENTO HIGH EFFICIENCY FAN

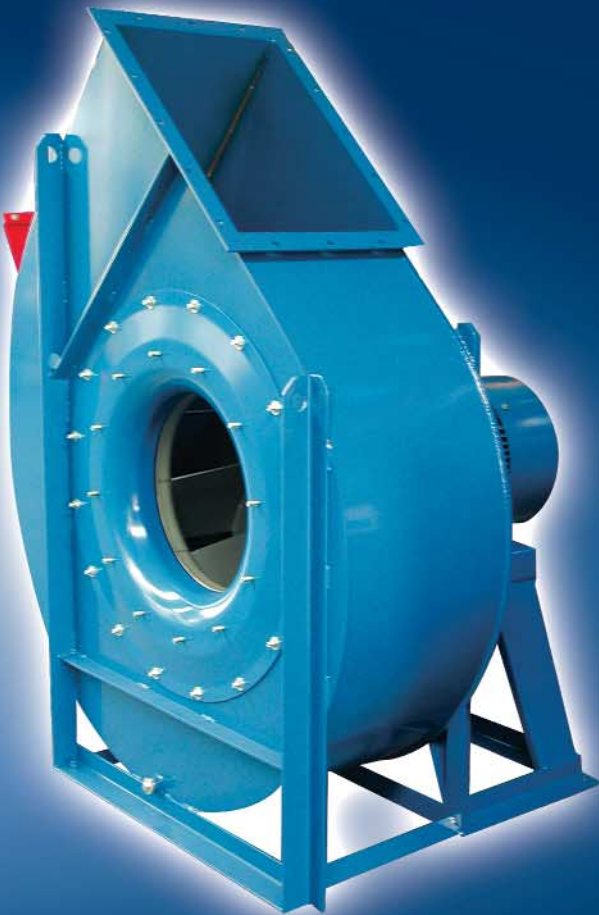

Ventilatore ad alto rendimento: Mod. RM.

Campo di lavoro: portate elevate, pressioni medie, rendimento elevato.
Tipo di pale: rovesce. Applicazioni: aspirazione e trasporto di aria anche molto polverosa, trasporto pneumatico, impianti di essiccazione, segatura, trucioli vari, materiali granulari, ad esclusione dei materiali filamentososi.
Temperatura del fluido: fino a 60° C in esecuzione standard; esecuzioni speciali per temperature superiori.
Caratteristiche costruttive: costruzione robusta in lamiera verniciata, ventola in acciaio equilibrata staticamente e dinamicamente.
Caratteristiche di funzionamento: condizioni dell'aria in aspirazione $T = 15^{\circ} \text{C}$, $p = 1 \text{ atm}$.

High efficiency fan: Mod. RM.

Field of application: high capacities, medium pressures, high performance.
Type of blades: backward.
Applications: suction and transport of air, pneumatic transport, drying systems, sawdust, woodchips, granulated materials with the exclusion of fibrous materials.
Air temperature: up to 60° C standard, special features for higher temperatures.
Construction specifications: rigid construction in sheet metal. Statically and dynamically balanced impellers.
Working principles: condition of the ducted air $T = 15^{\circ} \text{C}$, $p = 1 \text{ atm}$.



Orientamento RD 270
Position RD 270

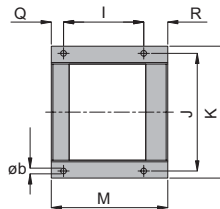
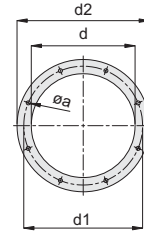
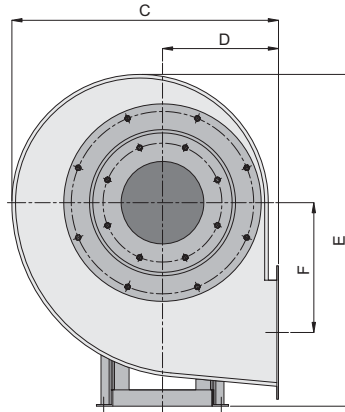
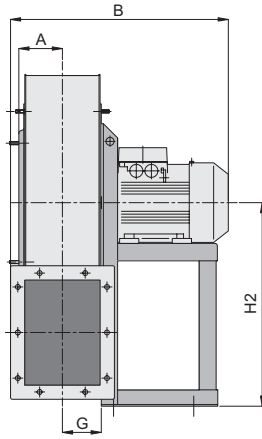
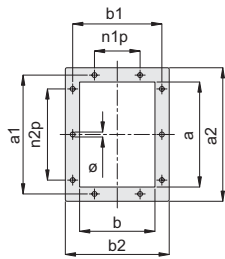

RM 220÷500

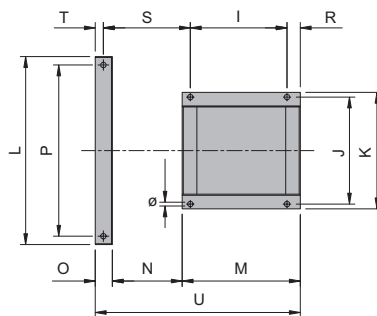
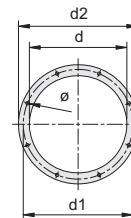
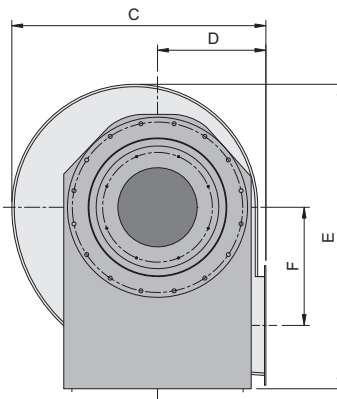
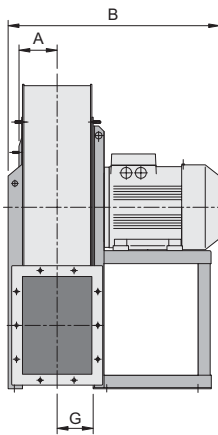
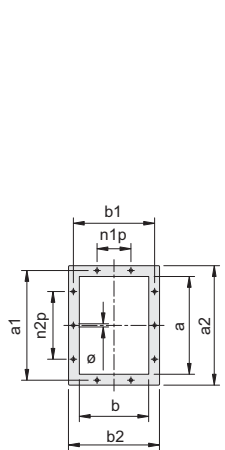

RM 560÷630

Direzioni di rotazione (vista lato motore) - Rotation senses (seen from motor side)

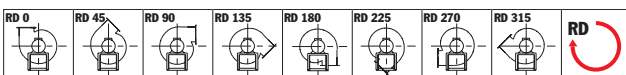

Rotazione oraria - Clockwise rotation sense

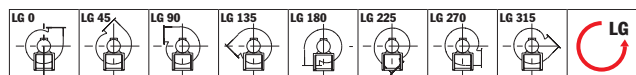

Rotazione anti-oraria - Anti-Clockwise rotation sense

DIMENSIONI D'INGOMBRO

OVERALL DIMENSIONS



RM 220÷630

TIPO - TYPE		PESO WEIGHT	PD² GD²	VENTILATORE FAN									
VENTILATORE FAN	MOTORE MOTOR			kgf	kgf m²	A	B	C	D	E	F	G	H
RM 220	63 A2	18	0,08	62	325	360	165	425	150	55	255	165	255
RM 251	63 B2	24	0,09	86	380	441	195	526	175	76	315	195	315
RM 252	71 A2	26	0,10		400								
RM 281	71 B2	30	0,15	95	420	477	200	610	202	86	375	200	375
RM 282	80 A2	32	0,16		440								
RM 311	80 B2	41	0,19	105	460	527	225	658	229	96	400	225	400
RM 312	90 S2	44	0,21		480								
RM 351	90 S2	66	0,43	115	500	600	255	740	253	107	450	255	450
RM 352	90 L2	69	0,50		530								
RM 401	100 LA2	107	0,70	127	590	655	285	815	286	118	500	285	500
RM 402	112 M2	110	0,80		630								
RM 451	132 SA2	150	1,2	141	670	735	320	915	321	131	560	320	560
RM 452	132 SB2	158	1,4		670								
RM 501	160 M2	235	2,3	157	830	832	360	1000	355	148	600	360	600
RM 502	160 M2	247	2,6		830								
RM 503	90 S4	132	2,1		580								
RM 504	90 L4	135	2,2		615								
RM 561	160 L2	286	3,4	177	880	940	400	1126	390	165	670	400	670
RM 562	180 M2	316	3,8		935								
RM 563	100 L4	140	3,2		705								
RM 564	100 L4	144	3,3		705								
RM 631	112 M4	178	5,6	195	775	1052	450	1260	439	185	750	450	750
RM 632	132 S4	191	6,3		815								

Peso ventilatore in Kgf (completo di motore)
 Weight of ventilator (complete with motor)
NOTA: quota B indicativa
 NOTE: "B" quote indicative

TIPO - TYPE	FLANGIA ASPIRANTE INLET FLANGE					FLANGIA PREMENTE OUTLET FLANGE										BASAMENTO BASE															
	VENTILATORE FAN	d	d ₁	d ₂	n°	∅	a	b	a ₁	b ₁	a ₂	b ₂	n ₁ xp	n ₂ xp	n°	∅	I	J	K	L	M	N	O	P	Q	R	S	T	U	∅	
RM 220		130	150	170	4	8	124	103	145	125	164	143	-	-	4	8	86	184	206	-	145	-	-	-	45	14	-	-	-	-	10
RM 251		185	219	255	8	8	207	148	241	182	277	218	1x112	1x112	8	12	86	184	206	-	145	-	-	-	45	14	-	-	-	-	10
RM 252													121	203	225	-	189	-	-	-	45	23	-	-	-	-					
RM 281		205	241	275	8	8	231	166	265	200	301	236	1x112	1x112	8	12	121	203	225	-	189	-	-	-	45	23	-	-	-	-	10
RM 282													211	-	-	-	45	45	-	-	-	-	-								
RM 311		228	265	298	8	8	258	185	292	219	328	255	1x112	2x112	10	12	121	203	225	-	211	-	-	-	45	45	-	-	-	-	10
RM 312													133	234	260	-	246	-	-	-	55	58	-	-	-						
RM 351		255	292	325	8	10	288	205	332	249	368	285	1x125	2x125	10	12	133	234	260	-	246	-	-	-	55	58	-	-	-	-	10
RM 352													-	-	-	-	55	58	-	-	-	-	-								
RM 401		285	332	365	8	12	322	229	366	273	402	309	1x125	2x125	10	12	197	289	324	-	276	-	-	-	30	49	-	-	-	-	12
RM 402													-	-	-	-	30	49	-	-	-	-	-								
RM 451		320	366	400	8	12	361	256	405	300	441	336	1x125	2x125	10	12	237	337	372	-	336	-	-	-	40	59	-	-	-	-	12
RM 452													-	-	-	-	40	59	-	-	-	-	-								
RM 501		360	405	440	8	12	404	288	448	332	484	368	2x125	3x125	14	12	337	395	440	-	436	-	-	-	50	49	-	-	-	-	14
RM 502													337	395	440	-	436	-	-	-	50	49	-	-	-						
RM 503													133	234	260	-	246	-	-	-	55	58	-	-	-						
RM 504													133	234	260	-	246	-	-	-	55	58	-	-	-						
RM 561		405	448	485	12	12	453	322	497	366	533	402	2x125	3x125	14	12	337	395	440	-	436	-	-	-	49	406	-	-	-	-	14
RM 562													357	434	488	-	460	-	-	-	33	426	-	-	-						
RM 563													197	289	324	692	460	326	53	632	-	49	386	23	839						
RM 564													197	289	324	276	49	386	629	12											
RM 631		455	497	535	12	12	507	361	551	405	587	441	2x125	3x125	14	12	197	289	324	762	276	365	53	702	-	49	425	23	668	12	
RM 632													237	337	762	762	336	-	59	435	718	12									

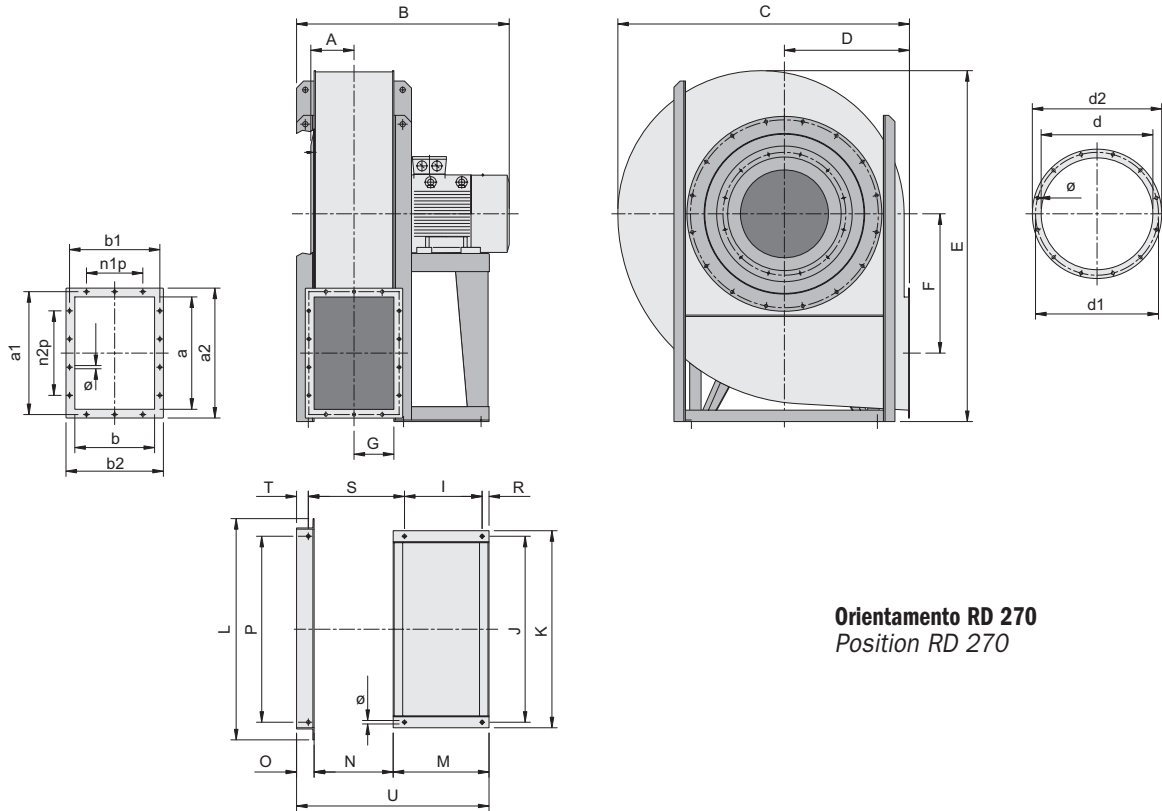

Orientamento RD 270
Position RD 270

RM 710÷1600

Direzioni di rotazione (vista lato motore) - Rotation senses (seen from motor side)

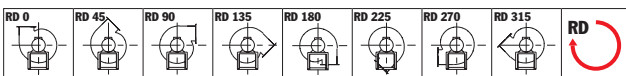

Rotazione oraria - Clockwise rotation sense

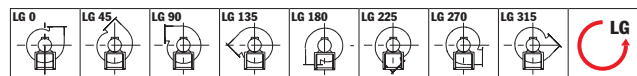

Rotazione anti-oraria - Anti-Clockwise rotation sense

DIMENSIONI D'INGOMBRO

OVERALL DIMENSIONS



RM 710÷1600

Peso ventilatore in Kgf (completo di motore) - Weight of ventilator (complete with motor)

NOTA: quota B Indicativa - NOTE: "B" quote indicative

TIPO - TYPE		PESO WEIGHT	PD² GD²	VENTILATORE FAN									
VENTILATORE FAN	MOTORE MOTOR			kgf	kgf m²	A	B	C	D	E	F	G	H
RM 711	132 M4	285	10,6	216	880	1189	500	1416	500	202	670	500	850
RM 712	160 M4	308	11,8		960								
RM 801	160 L4	400	17	241	1010	1340	560	1591	560	226	755	560	950
RM 802	180 M4	430	19		1050								
RM 803	132 M6	330	16		940								
RM 804	132 M6	340	18		940								
RM 901	200 L4	580	30	275	1230	1500	630	1780	630	253	850	630	1060
RM 902	225 S4	620	34		1260								
RM 903	160 M6	465	29		1070								
RM 904	160 L6	495	33		1070								
RM 1001	225 M4	760	48	308	1320	1685	710	1993	710	284	950	710	1180
RM 1002	250 M4	830	53		1380								
RM 1003	180 L6	652	47		1230								
RM 1004	200 L6	679	52		1300								
RM 1121	280 S4	1220	106	350	1620	1884	800	2222	800	319	1060	800	1320
RM 1122	280 M4	1257	118		1620								
RM 1123	200 L6	995	114		1390								
RM 1124	225 M6	1043	116		1410								
RM 1251	250 M6	1330	180	388	1550	2116	900	2517	900	357	1190	900	1500
RM 1252	280 S6	1405	190		1700								
RM 1401	280 M6	1850	300	442	1790	2325	1000	2816	1000	400	1320	1000	1700
RM 1402	315 S6	1970	315		1800								

TIPO - TYPE	FLANGIA ASPIRANTE INLET FLANGE					FLANGIA PREMENTE OUTLET FLANGE										BASAMENTO BASE																		
	VENTILATORE FAN	d	d ₁	d ₂	n°	∅	a	b	a ₁	b ₁	a ₂	b ₂	n _{1xp}	n _{2xp}	n°	∅	I	J	K	L	M	N	O	P	Q	R	S	T	U	∅				
RM 711	505	551	585	12	14	569	404	629	464	669	504	2x160	3x160	14	14	201	316	772	826	915	336	404	60	772	-	59	49	497	27	764	20			
RM 712																																436	49	948
RM 801	565	629	665	12	14	638	453	698	513	738	553	2x160	3x160	14	14	315	361	862	926	1045	436	453	80	862	-	39	59	546	47	993	20			
RM 802																																201	336	833
RM 803																																201	336	833
RM 804																																201	336	833
RM 901	635	698	735	12	14	715	507	775	567	815	607	2x160	4x160	16	14	401	441	962	1026	1145	500	507	80	962	-	39	39	600	47	1087	20			
RM 902																																540	436	1002
RM 903																																316	436	1002
RM 904																																316	436	1002
RM 1001	715	775	815	16	14	801	569	871	639	921	689	2x200	3x200	14	14	440	500	1056	1128	1255	540	569	100	1056	-	45	657	67	1209	20				
RM 1002																															460	460	1129	
RM 1003																															360	460	1129	
RM 1004																															400	500	1169	
RM 1121	805	861	905	16	14	898	638	968	708	1018	758	3x200	4x200	18	14	565	565	1178	1268	1400	690	638	100	1178	-	45	763	55	1428	24				
RM 1122																															375	500	1238	
RM 1123																															415	540	1278	
RM 1124																															415	540	1278	
RM 1251	905	958	1005	16	14	1007	715	1077	785	1127	835	3x200	4x200	18	14	475	565	1310	1400	1530	600	715	100	1310	-	45	840	55	1415	24				
RM 1252																															690	690	1505	
RM 1401	1007	1067	1107	24	14	1130	801	1210	881	1270	941	3x200	5x200	20	18	535	645	1450	1560	1690	690	801	130	1450	-	55	946	85	1621	24				
RM 1402																															800	800	1731	

CARATTERISTICHE IN MANDATA VENTILATORI SERIE "RM" OUTLET CHARACTERISTICS OF "RM" SERIES VENTILATORS

MOTORE A 4/6 POLI - 4/6 POLES MOTORS

TIPO - TYPE		MOTORE MOTOR				Qv m³/h																		
VENTILATORE FAN	MOTORE MOTOR	KW inst.	KW ass.	n	dB(A)	1700	1900	2150	2400	2700	3050	3450	3850	4250	4750	5400	6100	68500	7500	85000	95400	108000	120600	
RM 503	90 S4	1.1	1	1400	68																			
RM 504	90 L4	1.5	1.3	1400	69																			
RM 563	100 L4	2.2	1.8	1420	71																			
RM 564	100 L4	3	2.4	1430	72																			
RM 631	112 M4	4	3.4	1425	75																			
RM 632	132 S4	5.5	4.2	1440	78																			
RM 711	132 M4	7.5	6.5	1450	79																			
RM 712	160 M4	11	8	1460	81																			
RM 801	160 L4	15	12	1460	83																			
RM 802	180 M4	18.5	16	1470	84																			
RM 901	200 L4	30	25	1470	86																			
RM 902	225 S4	37	30	1475	87																			
RM 1001	225 M4	45	43	1475	90																			
RM 1002	250 M4	55	51	1475	91																			
RM 1121	280 S4	75	74	1475	93																			
RM 1122	280 M4	90	89	1480	94																			
RM 803	132 M6	4	3.4	960	73																			
RM 804	132 M6	5.5	4.2	960	74																			
RM 903	160 M6	7.5	7.1	965	76																			
RM 904	160 L6	11	8.9	965	77																			
RM 1003	180 L6	15	12	965	79																			
RM 1004	200 L6	18.5	16	970	80																			
RM 1123	200 L6	22	21	970	82																			
RM 1124	225 M6	30	28	975	83																			
RM 1251	250 M6	37	36	980	86																			
RM 1252	280 S6	45	44	980	87																			
RM 1401	280 M6	55	54	980	88																			
RM 1402	315 S6	75	74	985	91																			

TOLLERANZA SULLA PORTATA ±5% - LOAD TOLERANCE ±5% TOLLERANZA SULLA RUMOROSITÀ +3dB (A) - NOISE TOLERANCE +3dB (A) pt mmH2O= da Pa

Valori riferiti a: / Datas referring to: T=15°C; P=1 atm

PRESTAZIONI VENTILATORI A TRASMISSIONE BELT BELT DRIVEN FANS PERFORMANCES



RM 250T

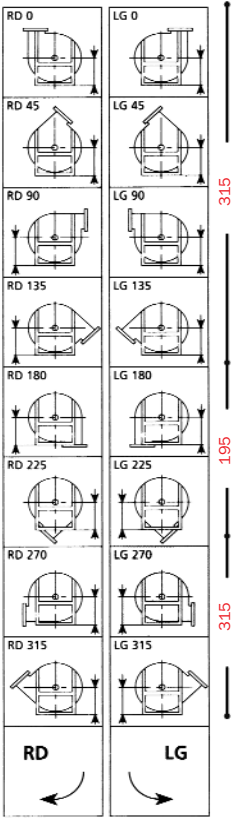

Il ventilatore è orientabile
The fan is revolvable

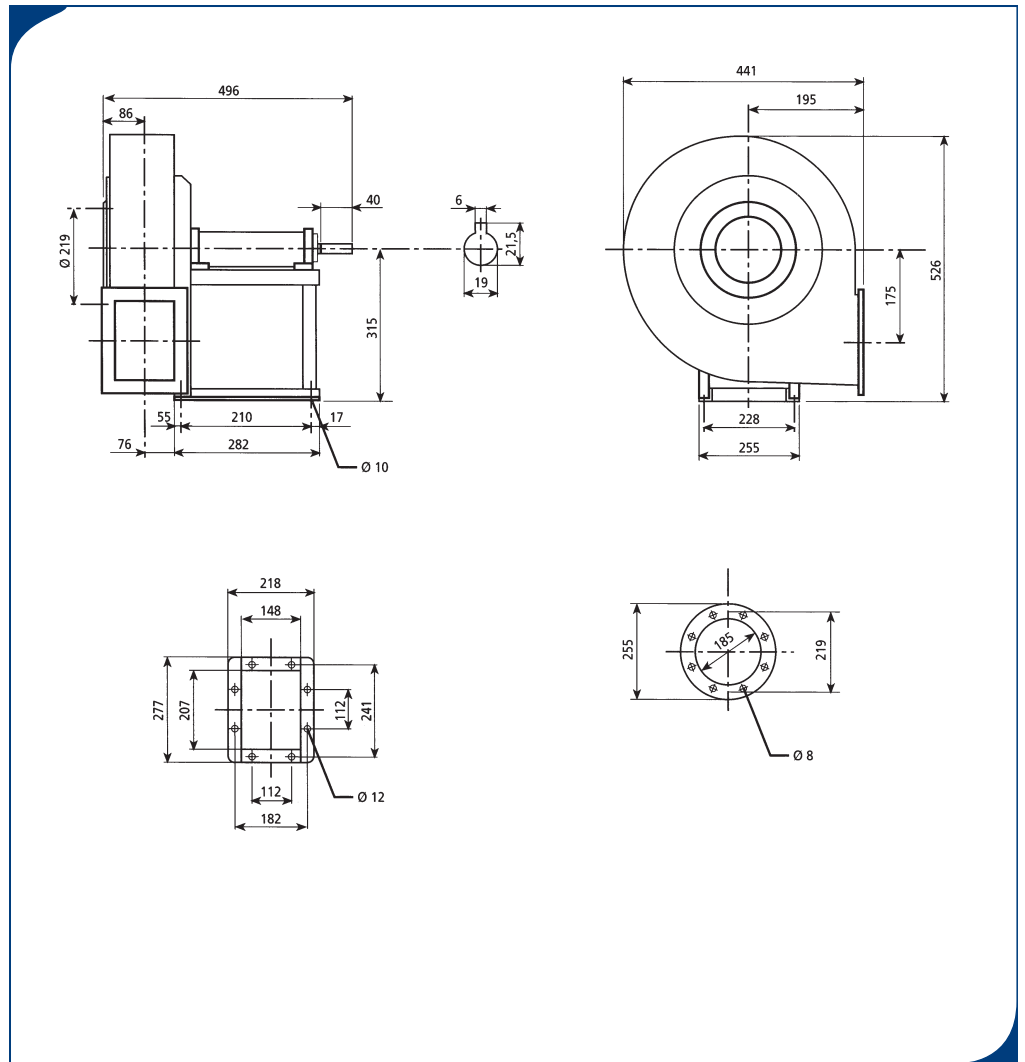

Peso ventilatore in kgf 25
Weight of ventilator in kgf 2,5

PD² = 0,10 kgf m²
GD² = 0,10 kgf m²

Massima velocità di rotazione
Maximum rotation speed

<100°C = 5600
100÷200°C = 5000
200÷300°C = 4500

Tolleranza sulla rumorosità + 3 dB(A)
Noise tolerance + 3 dB(A)

Tolleranza sulla potenza assorbita ± 3%
Absorbed power tolerance ± 3%

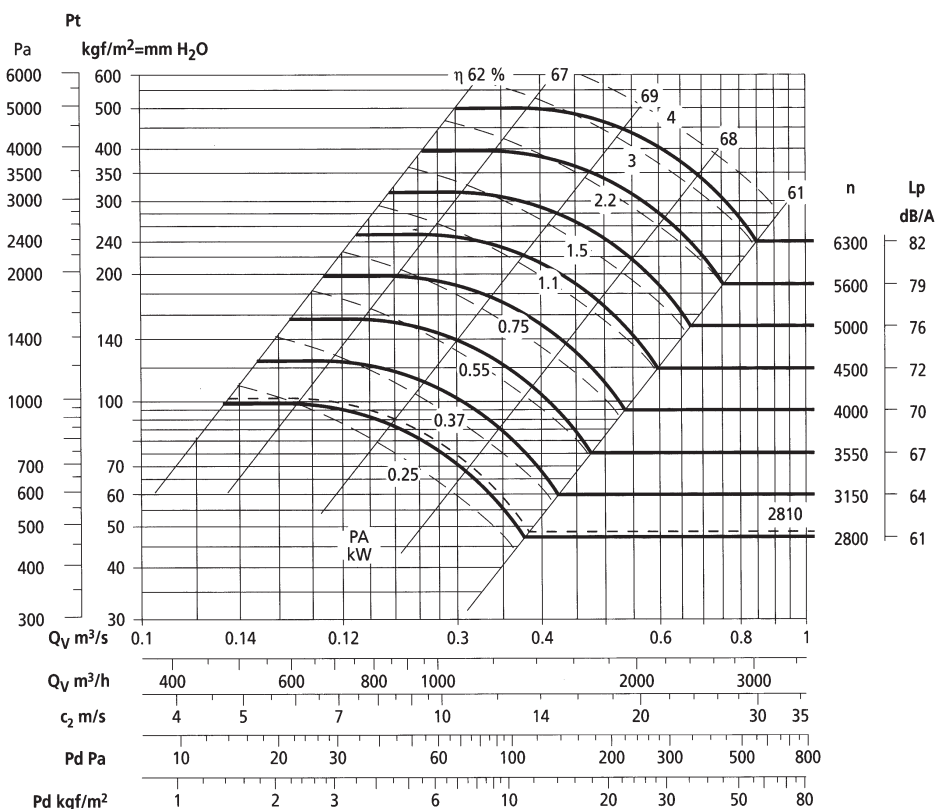



PRESTAZIONI VENTILATORI A TRASMISSIONE BELT DRIVEN FANS PERFORMANCES

RM 280T

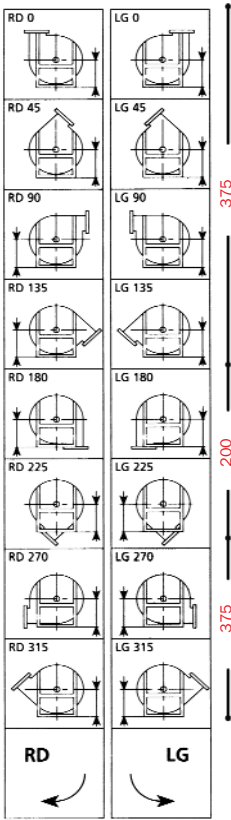

Il ventilatore è orientabile
The fan is revolvable

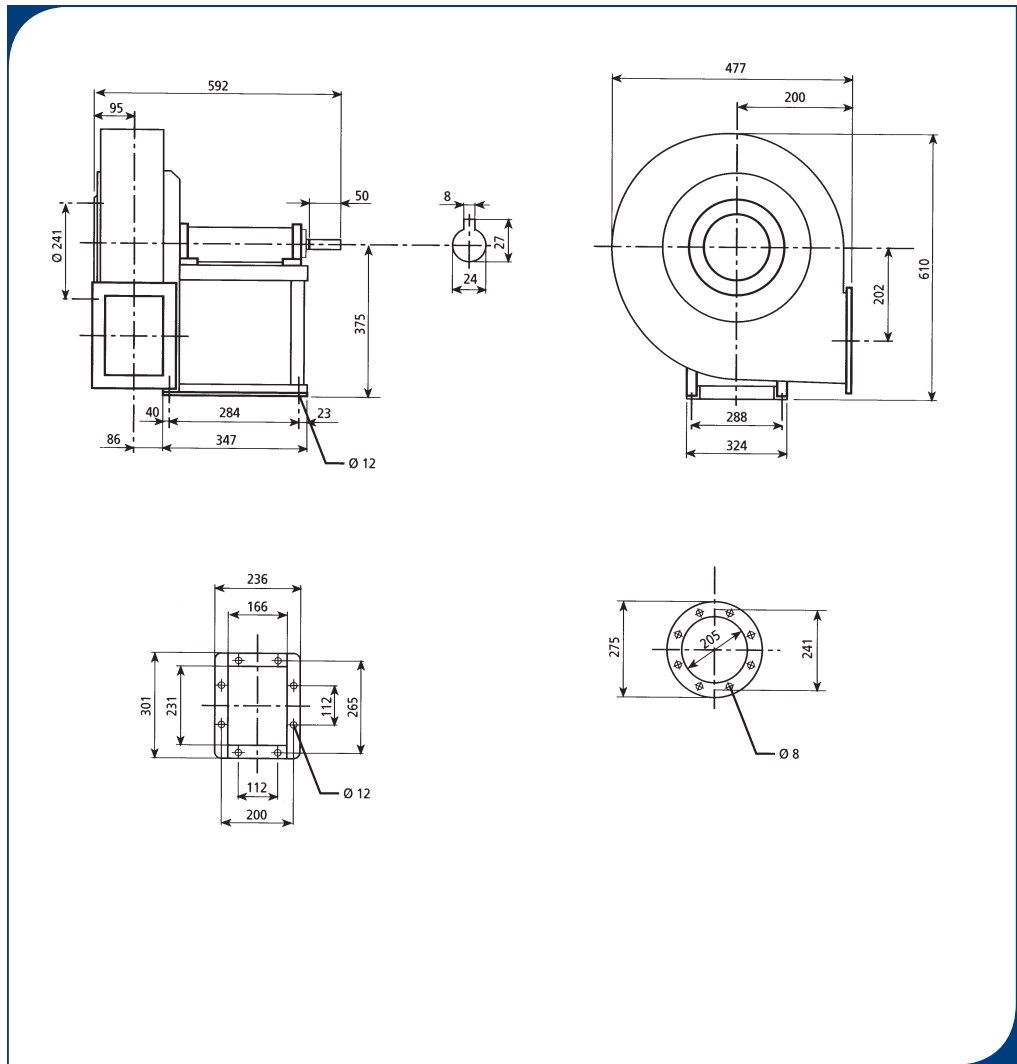

Peso ventilatore in kgf 36
Weight of ventilator in kgf 36

PD² = 0,16 kgf m²
GD² = 0,16 kgf m²

Massima velocità di rotazione
Maximum rotation speed

<100°C = 5000
100÷200°C = 4500
200÷300°C = 4000

Tolleranza sulla rumorosità + 3 dB(A)
Noise tolerance + 3 dB(A)

Tolleranza sulla potenza assorbita ± 3%
Absorbed power tolerance ± 3%

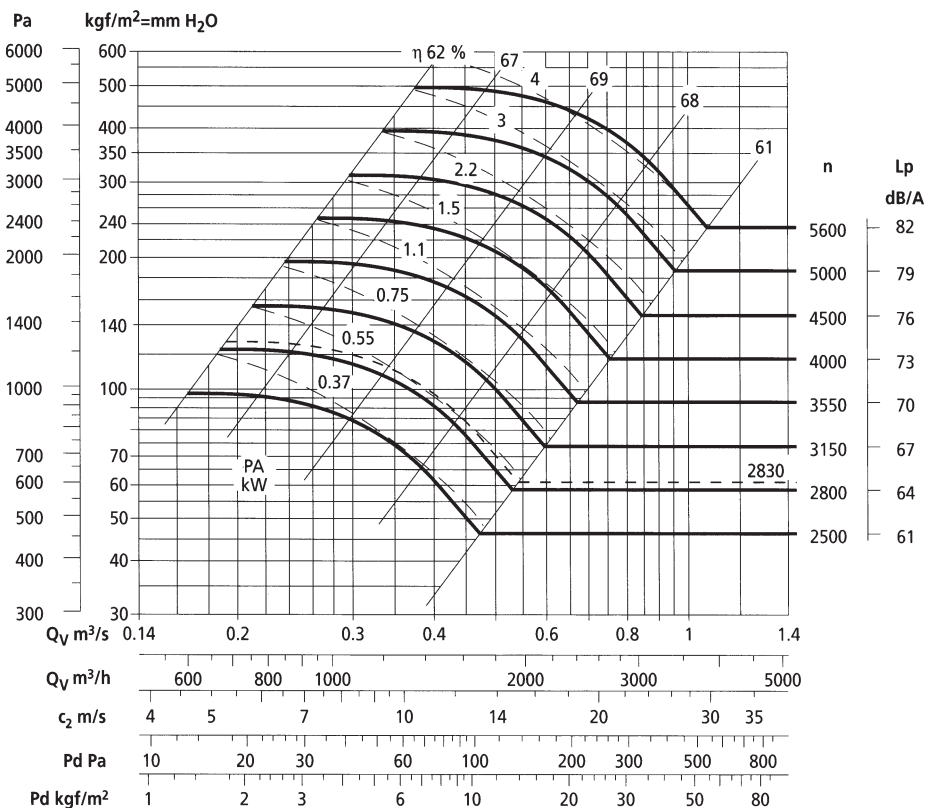

PRESTAZIONI VENTILATORI A TRASMISSIONE BELT BELT DRIVEN FANS PERFORMANCES



RM 310T

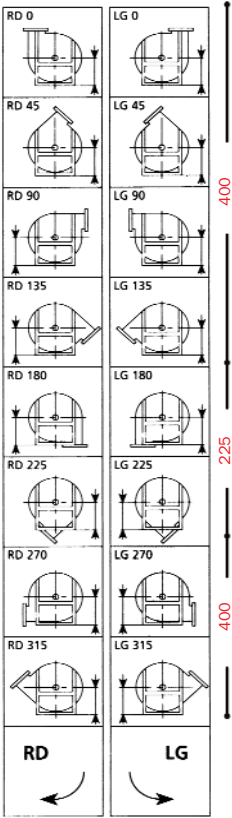

Il ventilatore è orientabile
The fan is revolvable

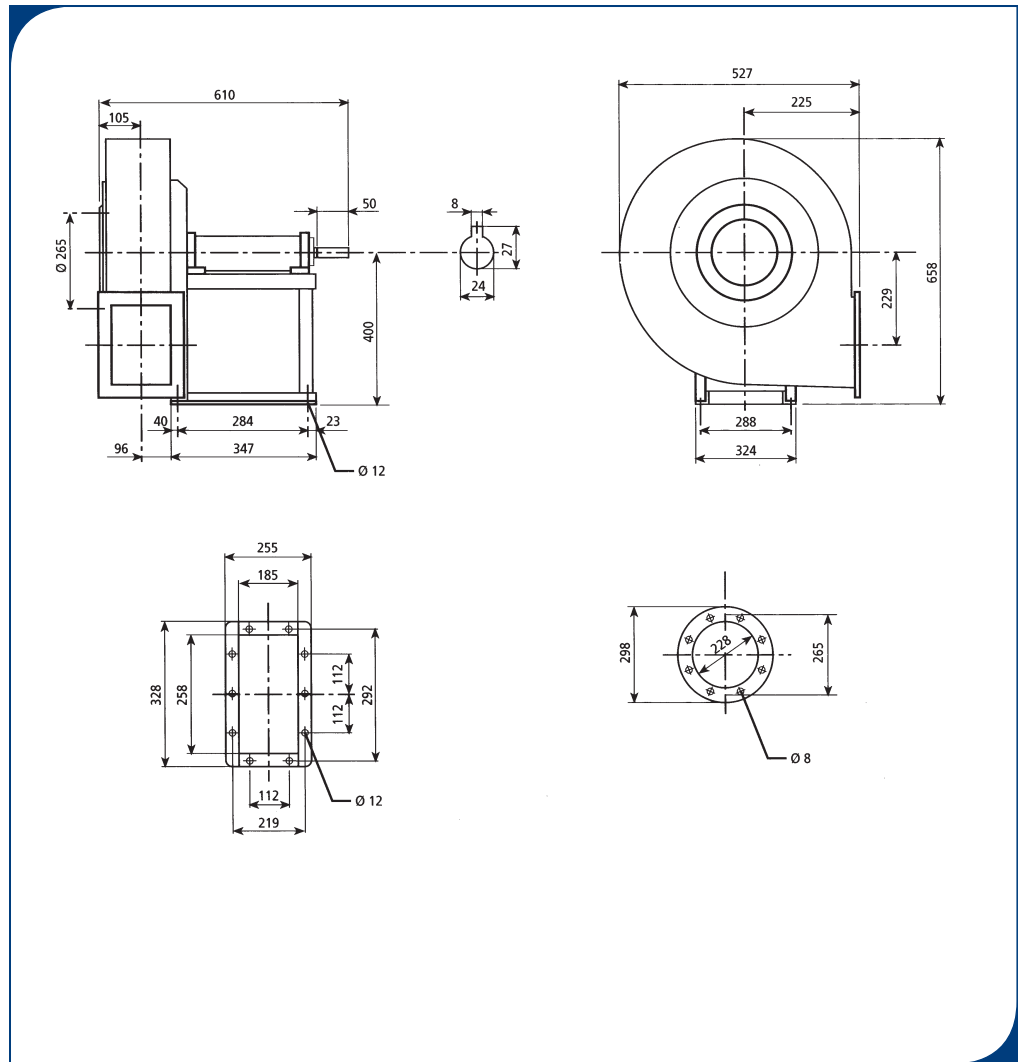

Peso ventilatore in kgf 43
Weight of ventilator in kgf 43

PD² = 0,21 kgf m²
GD² = 0,21 kgf m²

Massima velocità di rotazione
Maximum rotation speed

<100°C = 4500
100÷200°C = 4000
200÷300°C = 3550

Tolleranza sulla rumorosità + 3 dB(A)
Noise tolerance + 3 dB(A)

Tolleranza sulla potenza assorbita ± 3%
Absorbed power tolerance ± 3%

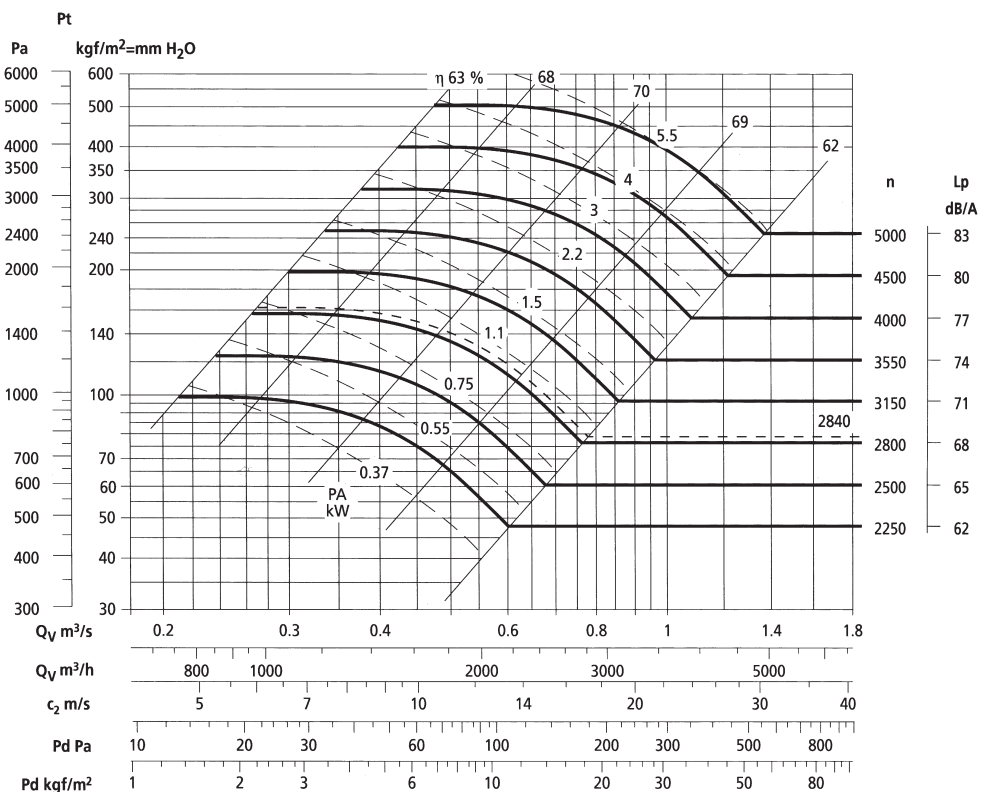



PRESTAZIONI VENTILATORI A TRASMISSIONE BELT DRIVEN FANS PERFORMANCES

RM 350T

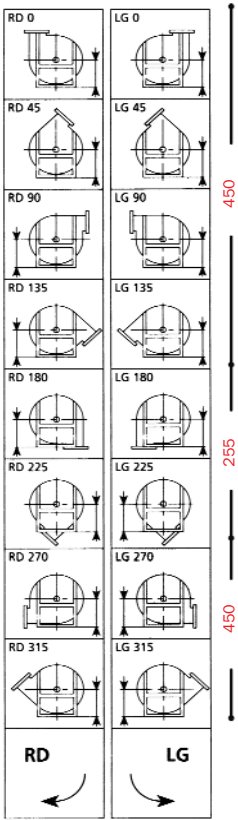

Il ventilatore è orientabile
The fan is revolvable

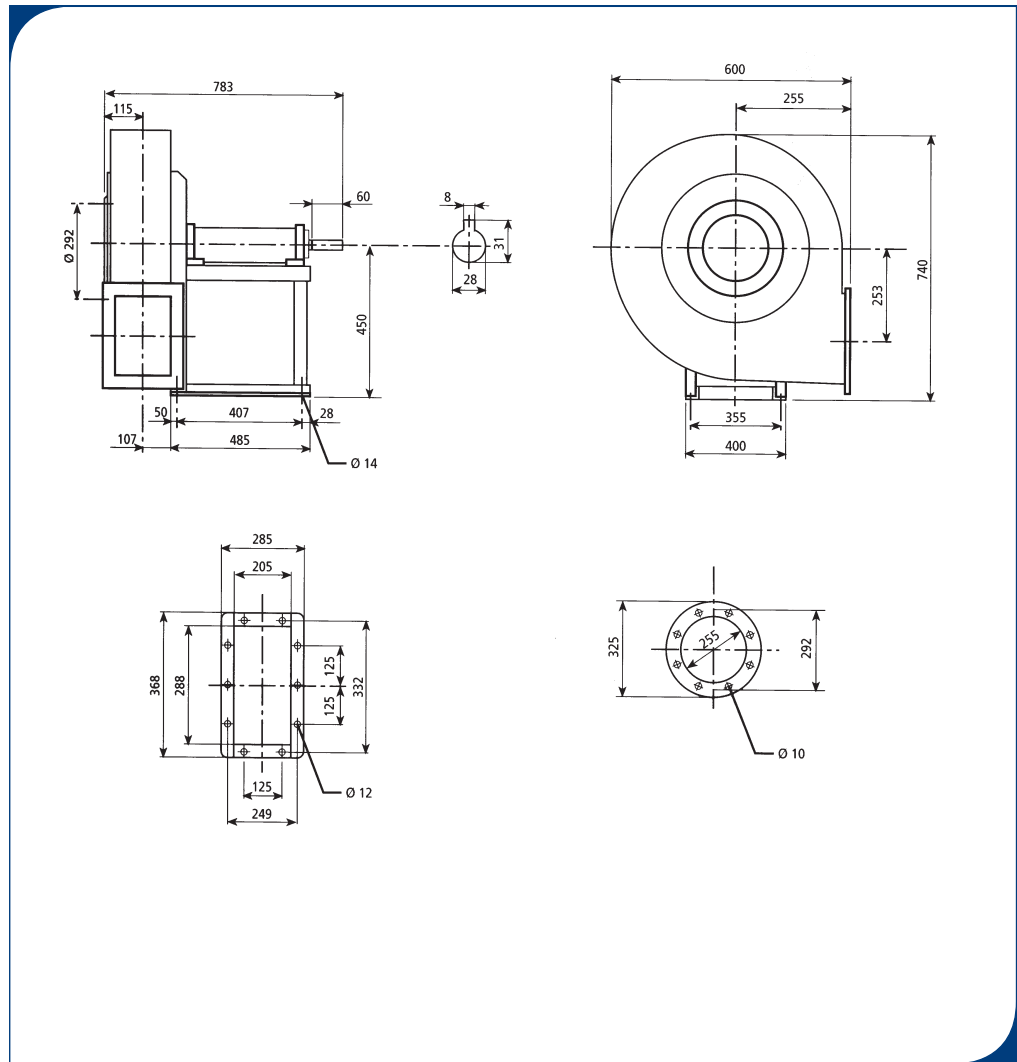

Peso ventilatore in kgf 72
Weight of ventilator in kgf 72

PD² = 0,5 kgf m²
GD² = 0,5 kgf m²

Massima velocità di rotazione
Maximum rotation speed

<100°C = 4000
100÷200°C = 3550
200÷300°C = 3150

Tolleranza sulla rumorosità + 3 dB(A)
Noise tolerance + 3 dB(A)

Tolleranza sulla potenza assorbita ± 3%
Absorbed power tolerance ± 3%

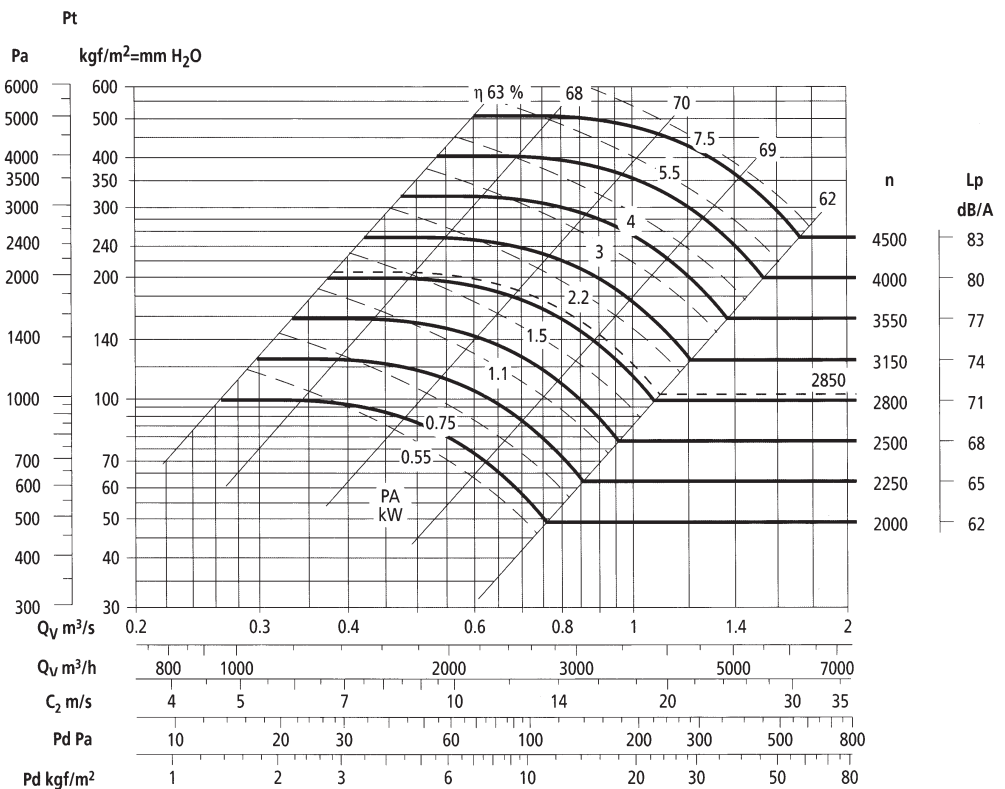

PRESTAZIONI VENTILATORI A TRASMISSIONE BELT BELT DRIVEN FANS PERFORMANCES



RM 400T

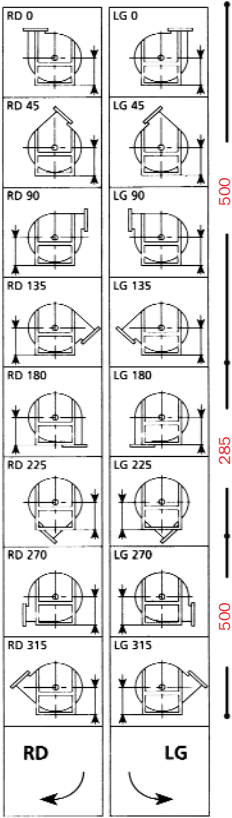

Il ventilatore è orientabile
The fan is revolvable

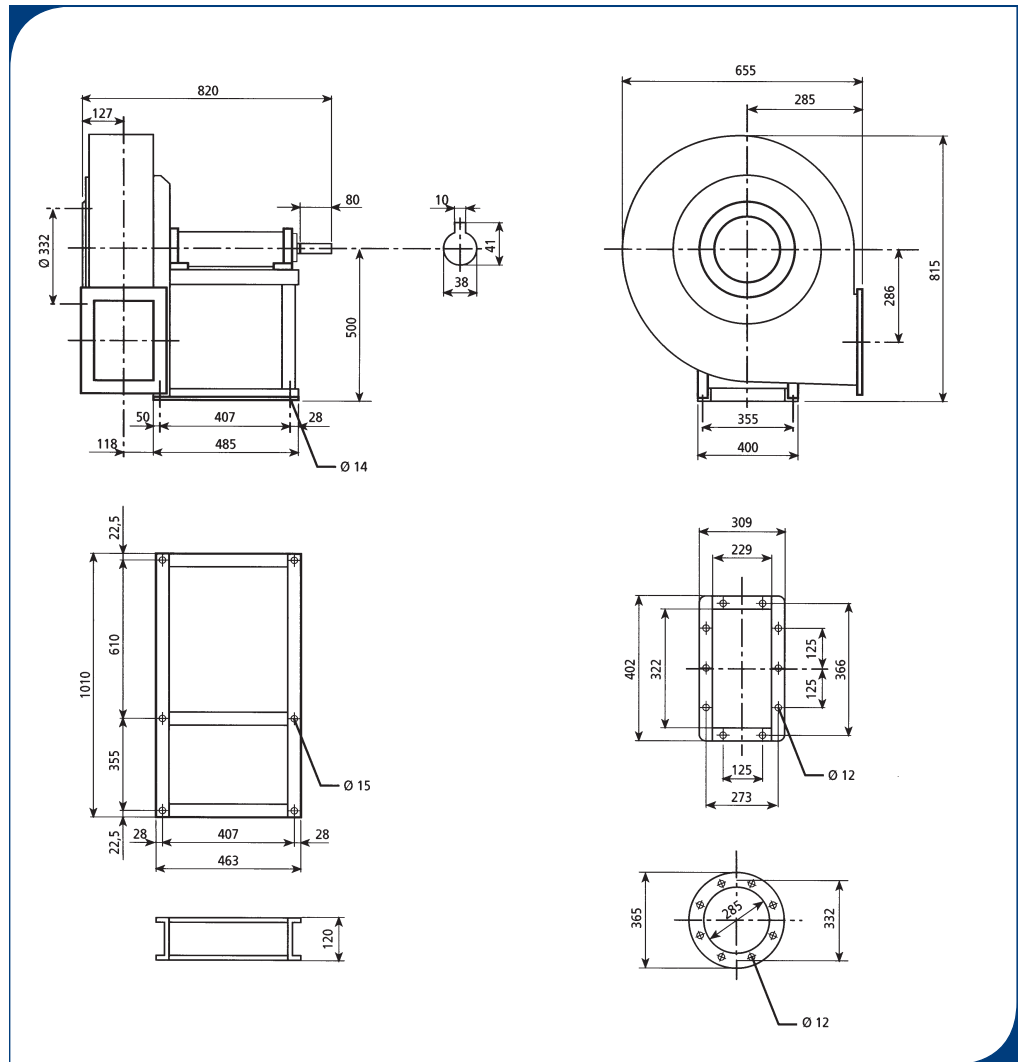

Peso ventilatore in kgf 85
Weight of ventilator in kgf 85

$PD^2 = 0,8 \text{ kgf m}^2$

Massima velocità di rotazione
Maximum rotation speed

<100°C = 3550
100÷200°C = 3150
200÷300°C = 2800

Tolleranza sulla rumorosità + 3 dB(A)
Noise tolerance + 3 dB(A)

Tolleranza sulla potenza assorbita ± 3%
Absorbed power tolerance ± 3%

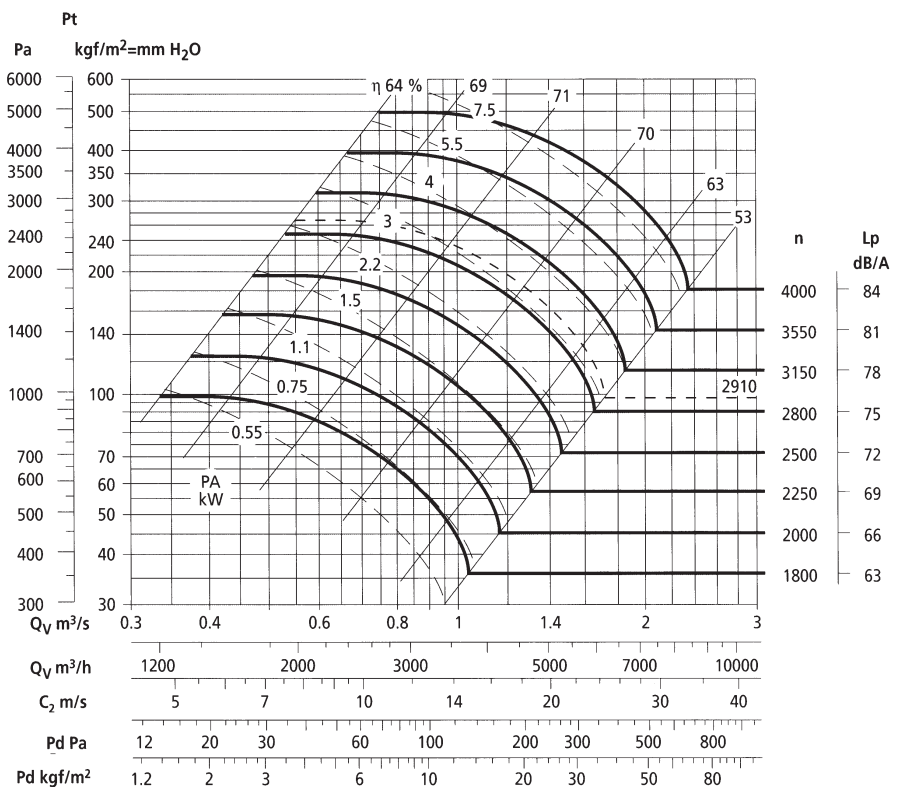



PRESTAZIONI VENTILATORI A TRASMISSIONE BELT DRIVEN FANS PERFORMANCES

RM 450T

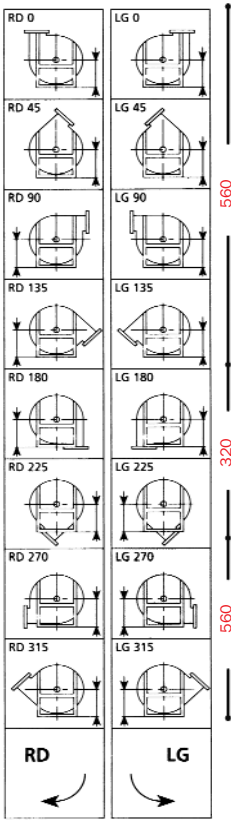

Il ventilatore **non** è orientabile
The fan is **not** revolvable

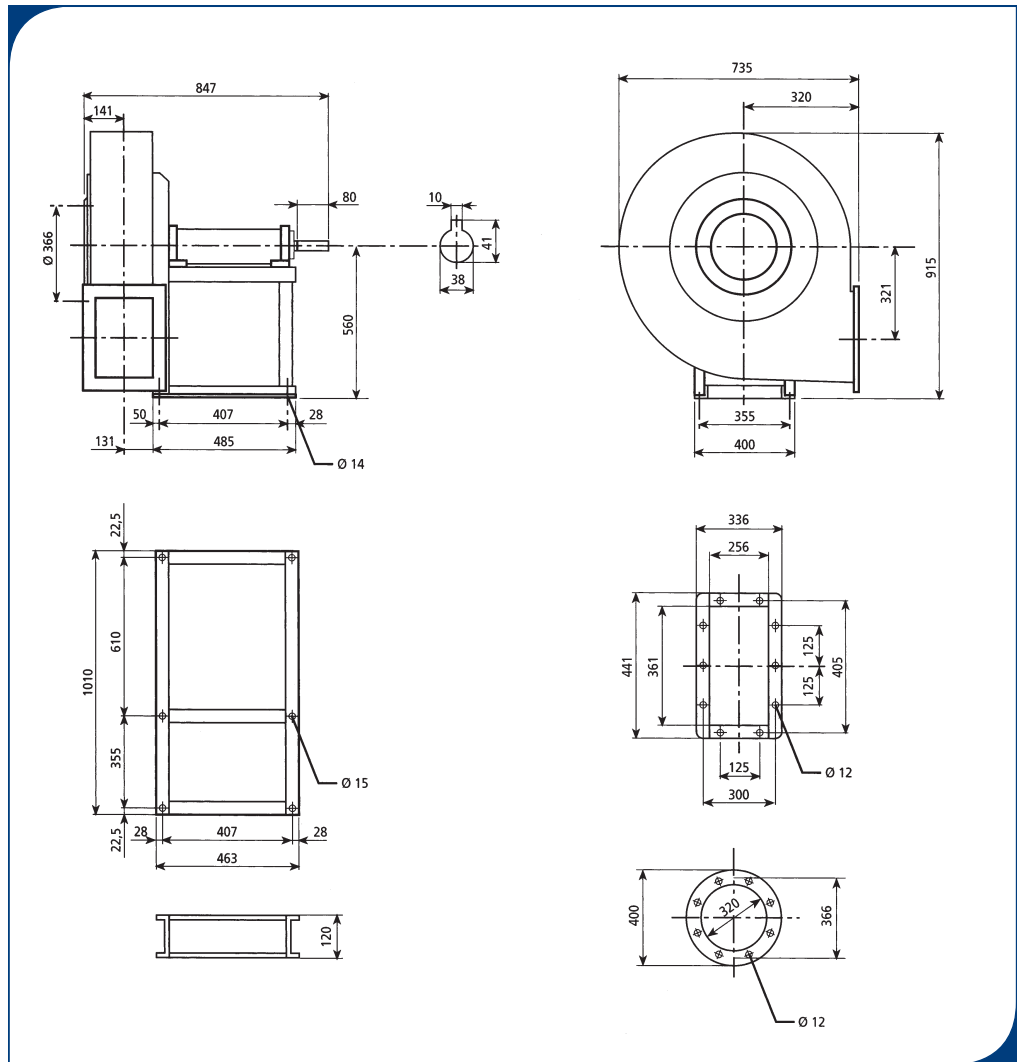

Peso ventilatore in kgf 102
Weight of ventilator in kgf 102

PD² = 1,4 kgf m²
GD² = 1,4 kgf m²

Massima velocità di rotazione
Maximum rotation speed

<100°C = 3150
100÷200°C = 2800
200÷300°C = 2500

Tolleranza sulla rumorosità + 3 dB(A)
Noise tolerance + 3 dB(A)

Tolleranza sulla potenza assorbita ± 3%
Absorbed power tolerance ± 3%

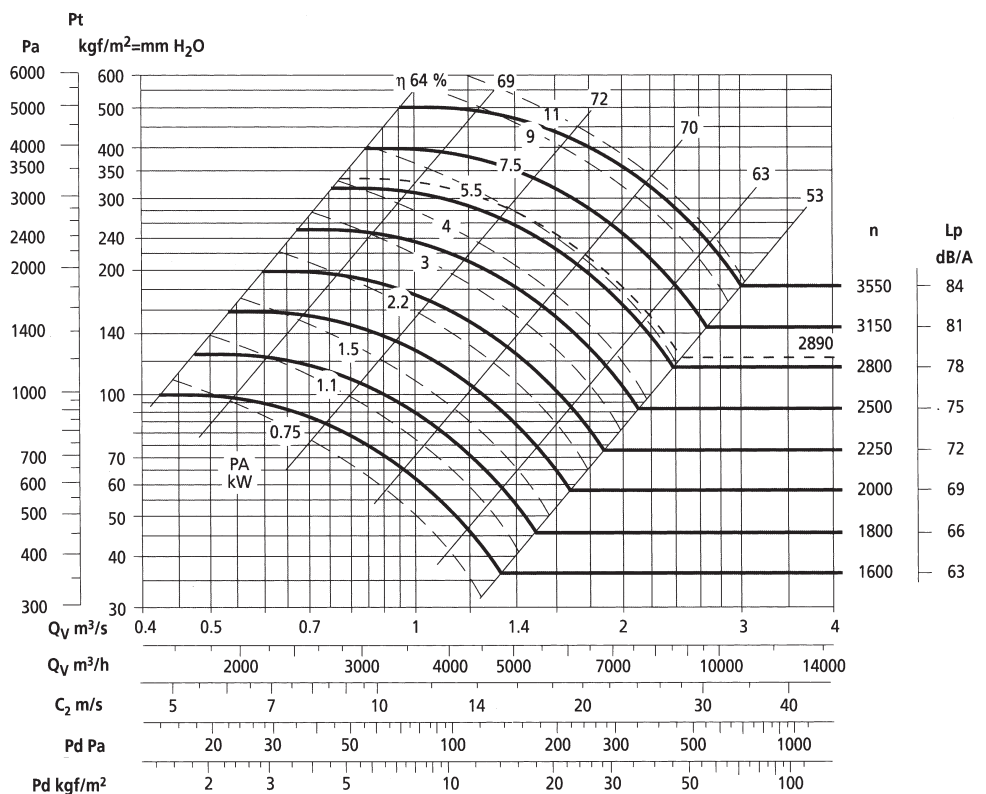



PRESTAZIONI VENTILATORI A TRASMISSIONE BELT DRIVEN FANS PERFORMANCES

RM 560T

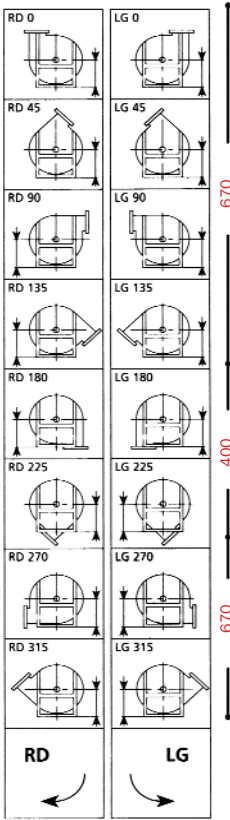

Il ventilatore **non** è orientabile
The fan is **not** revolvable

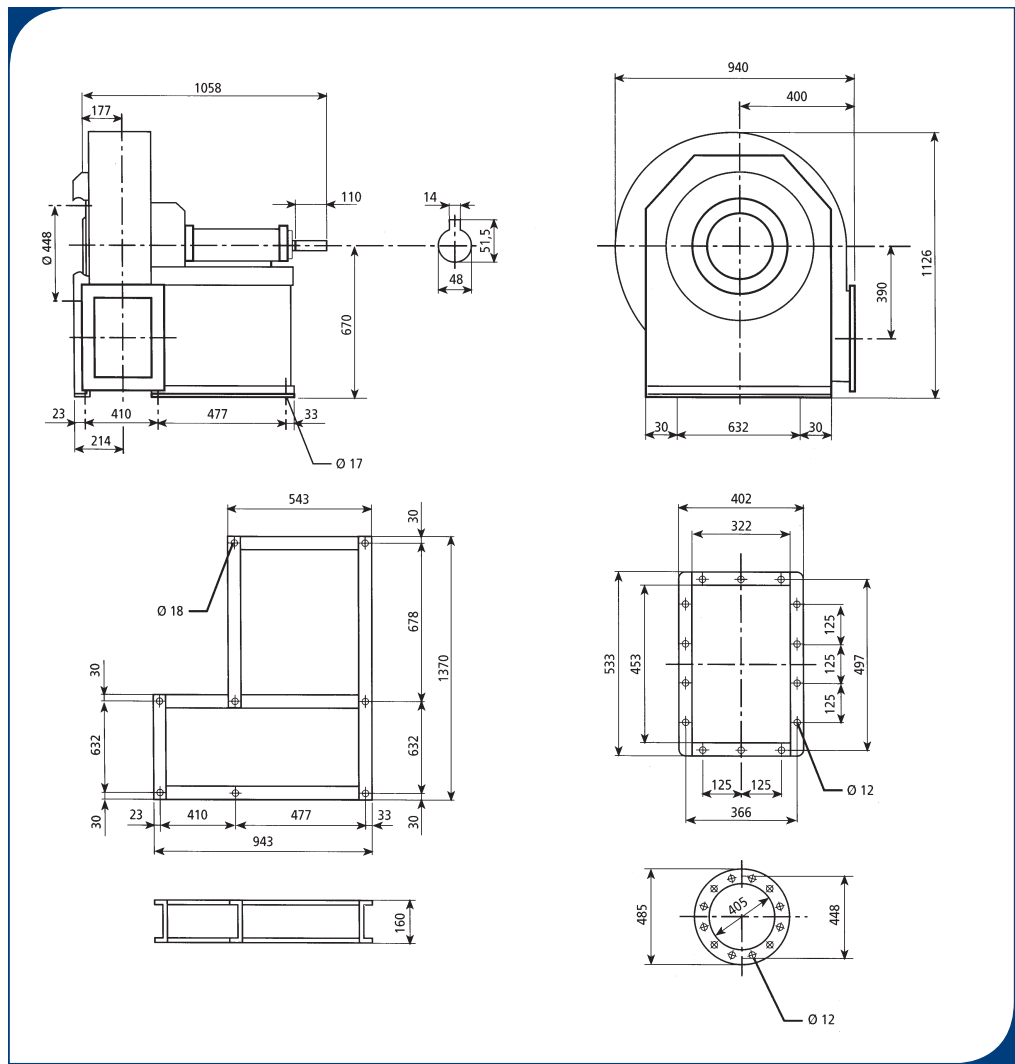

Peso ventilatore in kgf 172
Weight of ventilator in kgf 172

PD² = 3,8 kgf m²
GD² = 3,8 kgf m²

Massima velocità di rotazione
Maximum rotation speed

<100°C = 2500
100÷200°C = 2250
200÷300°C = 2000

Tolleranza sulla rumorosità + 3 dB(A)
Noise tolerance + 3 dB(A)

Tolleranza sulla potenza assorbita ± 3%
Absorbed power tolerance ± 3%

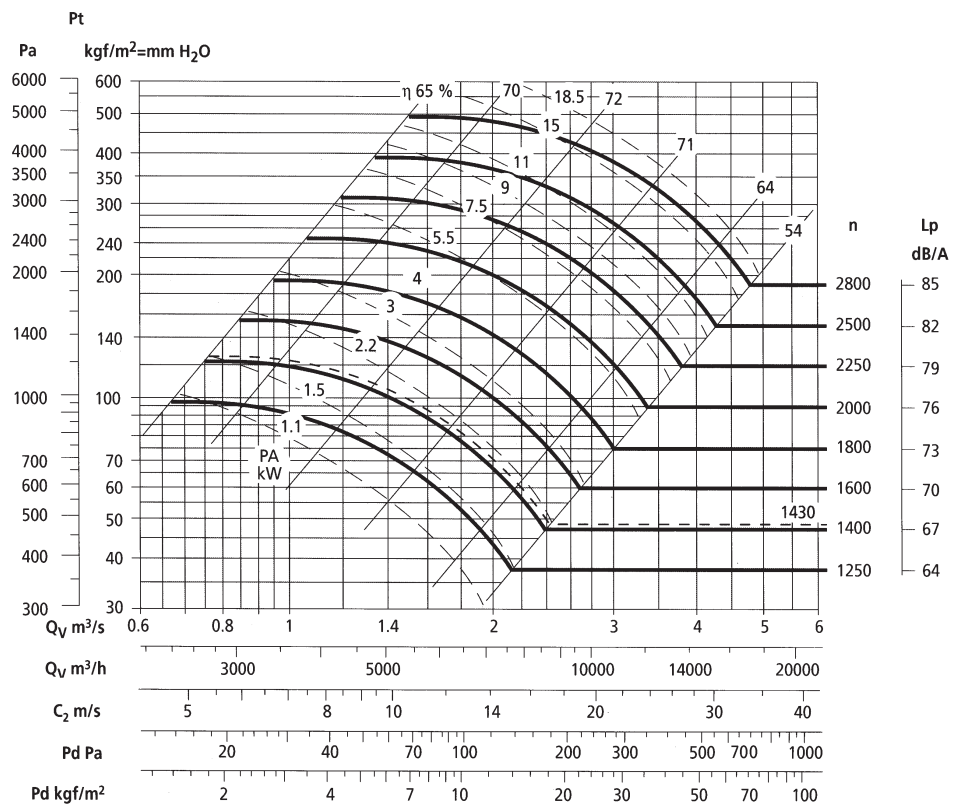

PRESTAZIONI VENTILATORI A TRASMISSIONE BELT BELT DRIVEN FANS PERFORMANCES



RM 630T

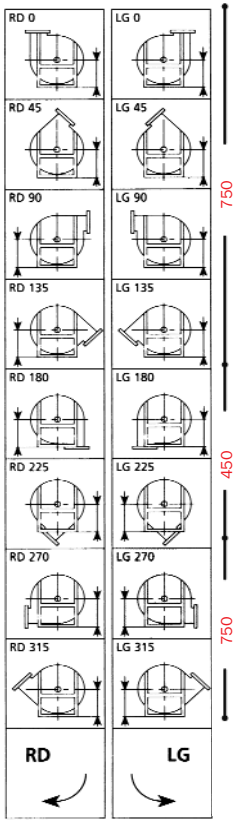

Il ventilatore **non** è orientabile
The fan is **not** revolvable

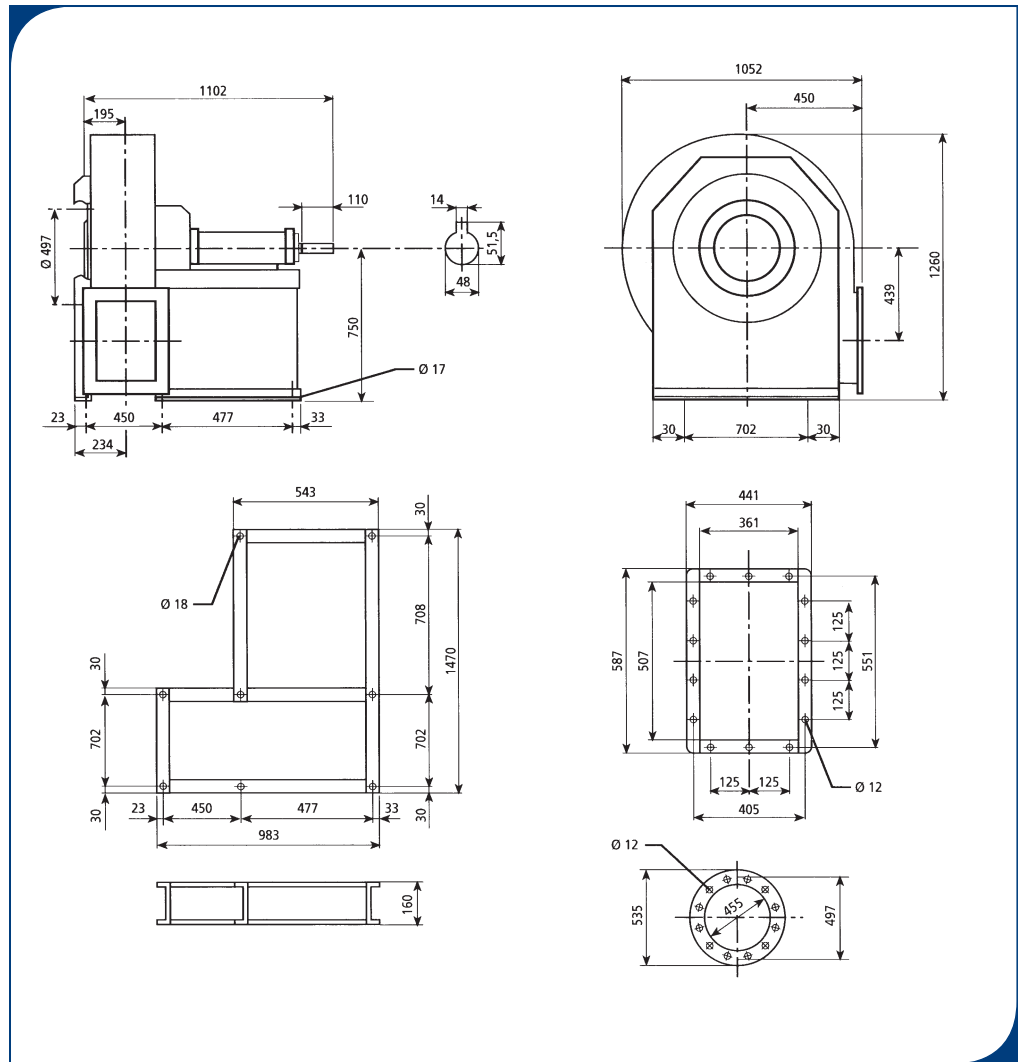

Peso ventilatore in kgf 210
Weight of ventilator in kgf 210

PD² = 6,7 kgf m²
GD² = 6,7 kgf m²

Massima velocità di rotazione
Maximum rotation speed

<100°C = 2250
100÷200°C = 2000
200÷300°C = 1800

Tolleranza sulla rumorosità + 3 dB(A)
Noise tolerance + 3 dB(A)

Tolleranza sulla potenza assorbita ± 3%
Absorbed power tolerance ± 3%

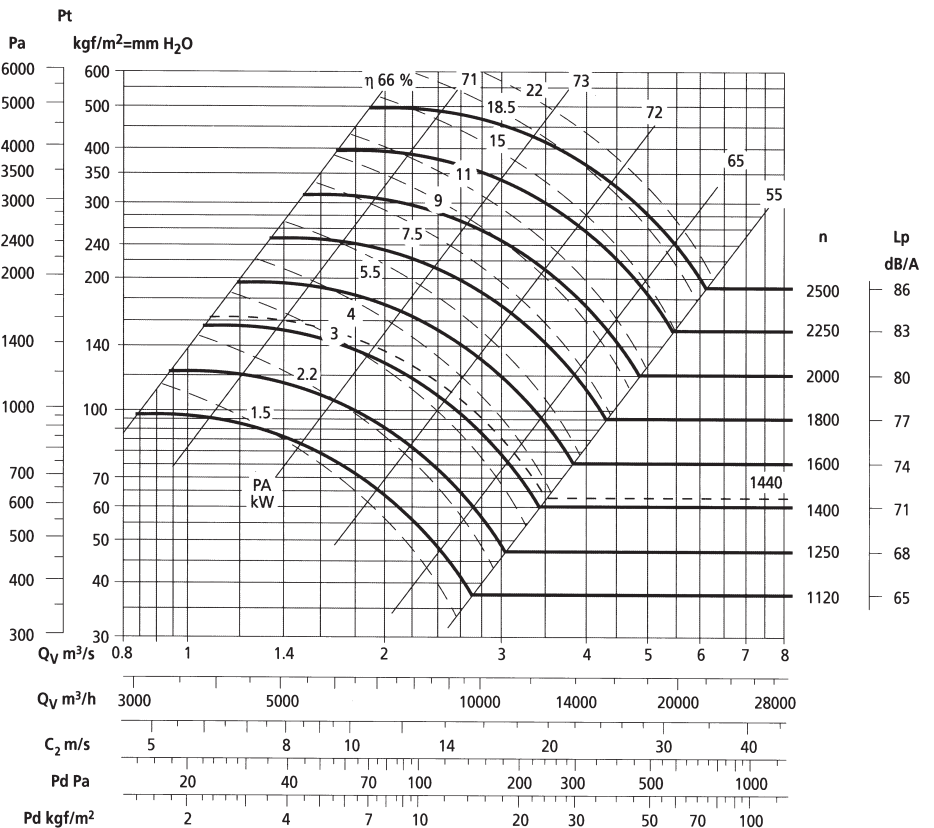



PRESTAZIONI VENTILATORI A TRASMISSIONE BELT DRIVEN FANS PERFORMANCES

RM 710T

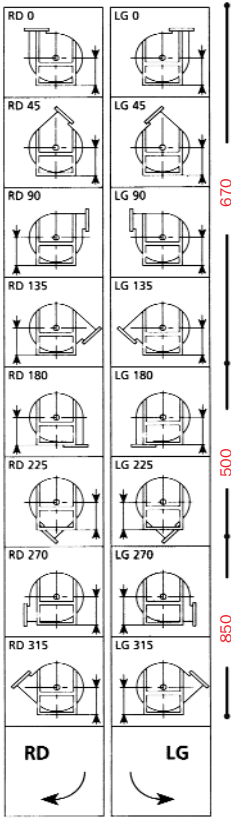

Il ventilatore **non** è orientabile
The fan is **not** revolvable

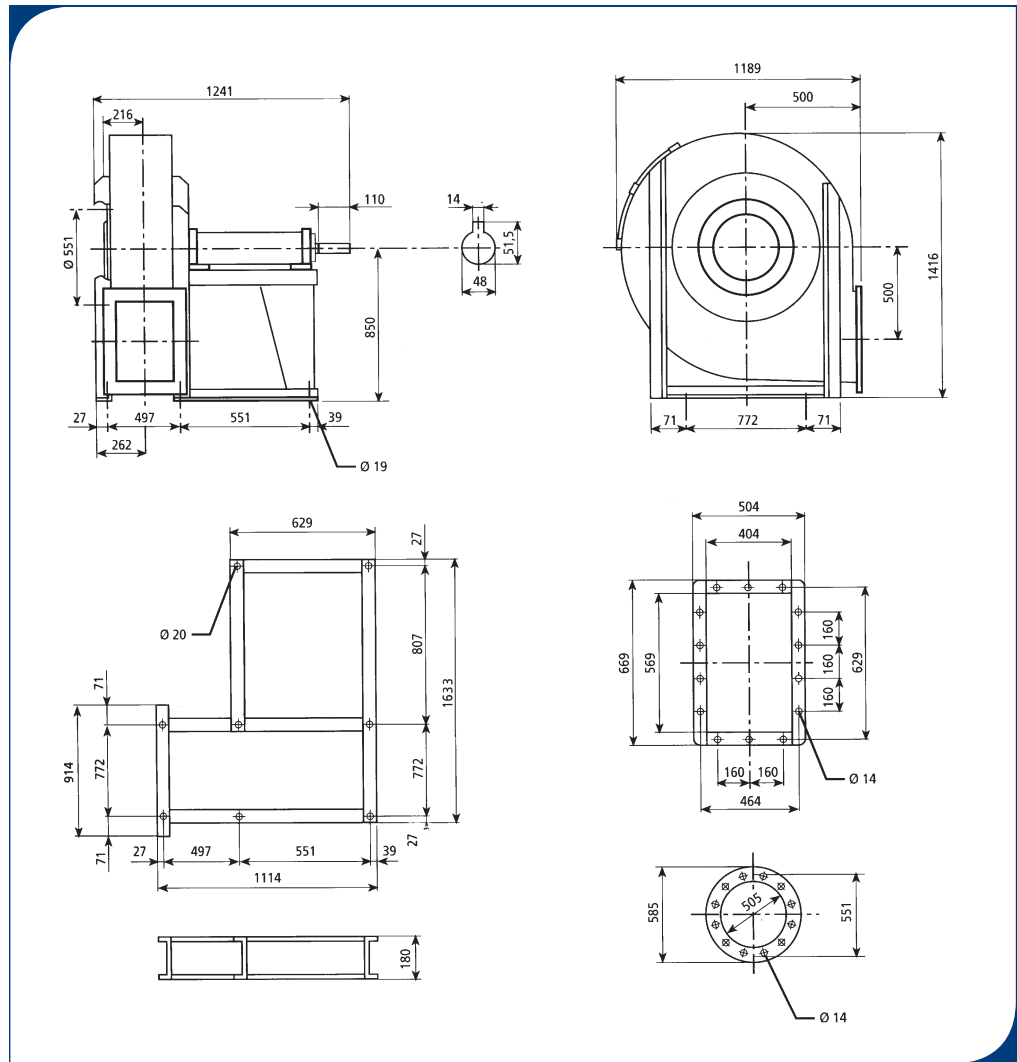

Peso ventilatore in kgf 290
Weight of ventilator in kgf 290

PD² = 12 kgf m²
GD² = 12 kgf m²

Massima velocità di rotazione
Maximum rotation speed

<100°C = 2000
100÷200°C = 1800
200÷300°C = 1600

Tolleranza sulla rumorosità + 3 dB(A)
Noise tolerance + 3 dB(A)

Tolleranza sulla potenza assorbita ± 3%
Absorbed power tolerance ± 3%

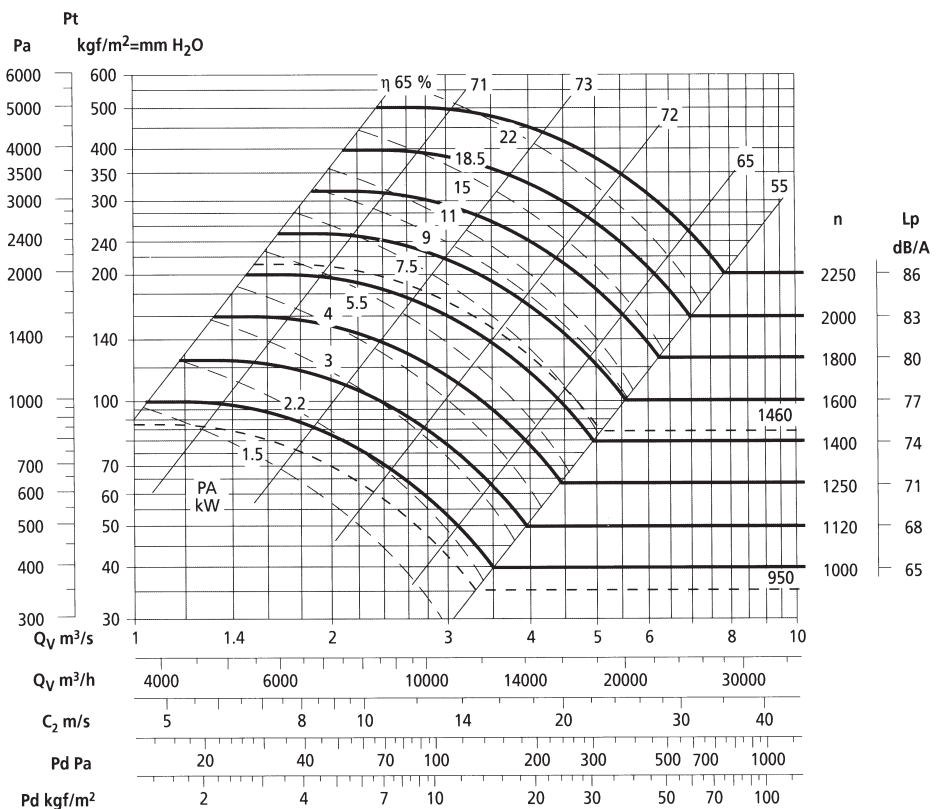

PRESTAZIONI VENTILATORI A TRASMISSIONE BELT BELT DRIVEN FANS PERFORMANCES



RM 800T

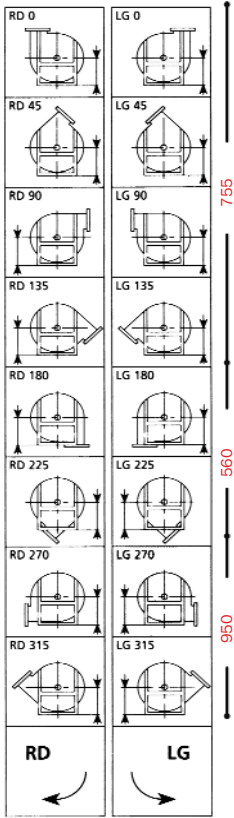

Il ventilatore **non** è orientabile
The fan is **not** revolvable

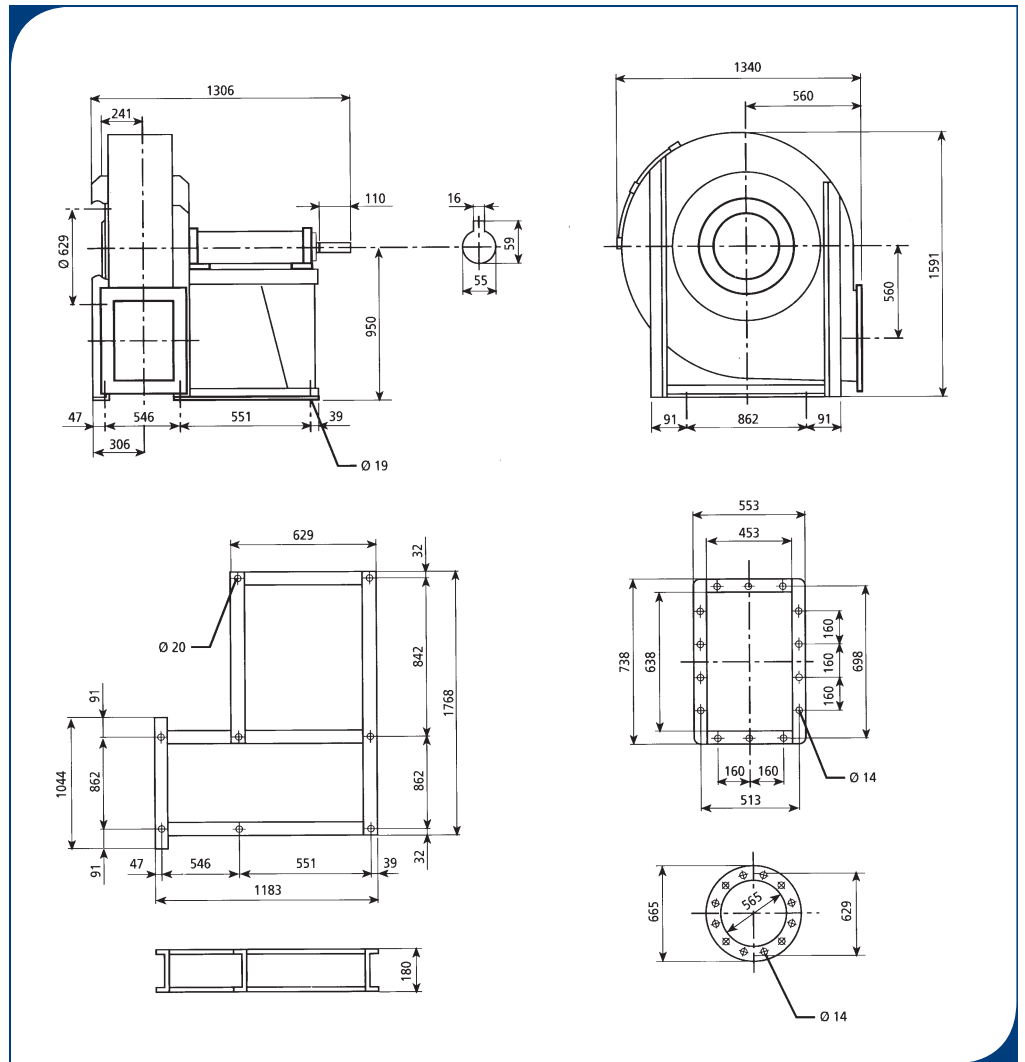

Peso ventilatore in kgf 340
Weight of ventilator in kgf 340

PD² = 19 kgf m²
GD² = 19 kgf m²

Massima velocità di rotazione
Maximum rotation speed

<100°C = 1800
100÷200°C = 1600
200÷300°C = 1400

Tolleranza sulla rumorosità + 3 dB(A)
Noise tolerance + 3 dB(A)

Tolleranza sulla potenza assorbita ± 3%
Absorbed power tolerance ± 3%

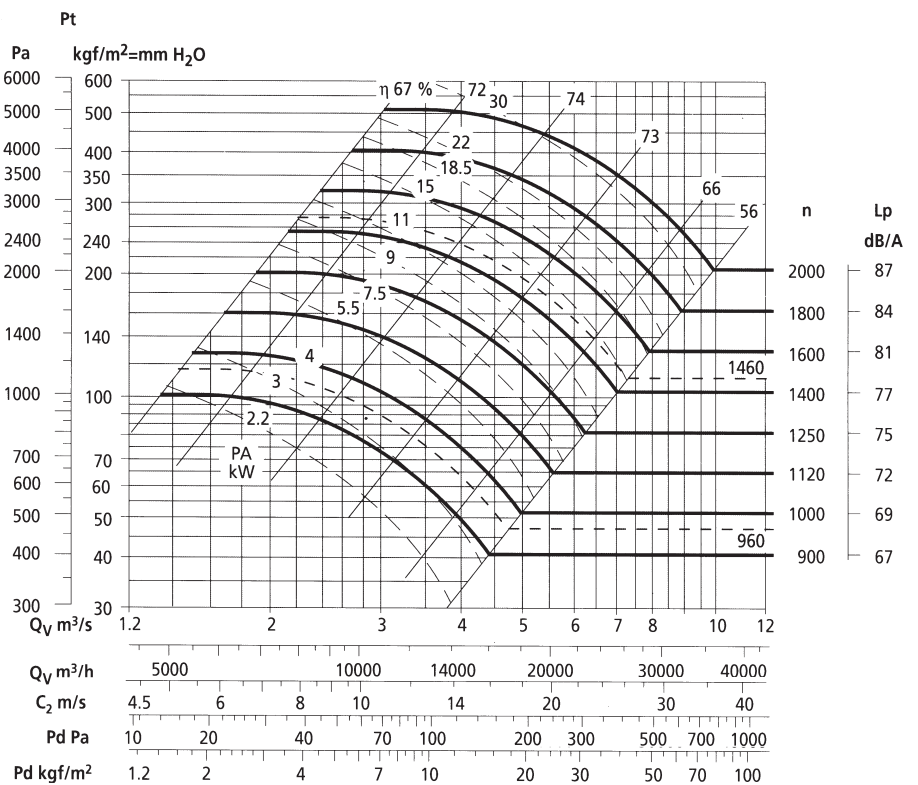



PRESTAZIONI VENTILATORI A TRASMISSIONE BELT DRIVEN FANS PERFORMANCES

RM 900T

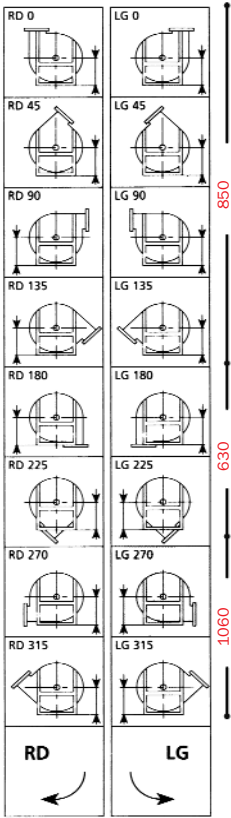

Il ventilatore **non** è orientabile
The fan is **not** revolvable

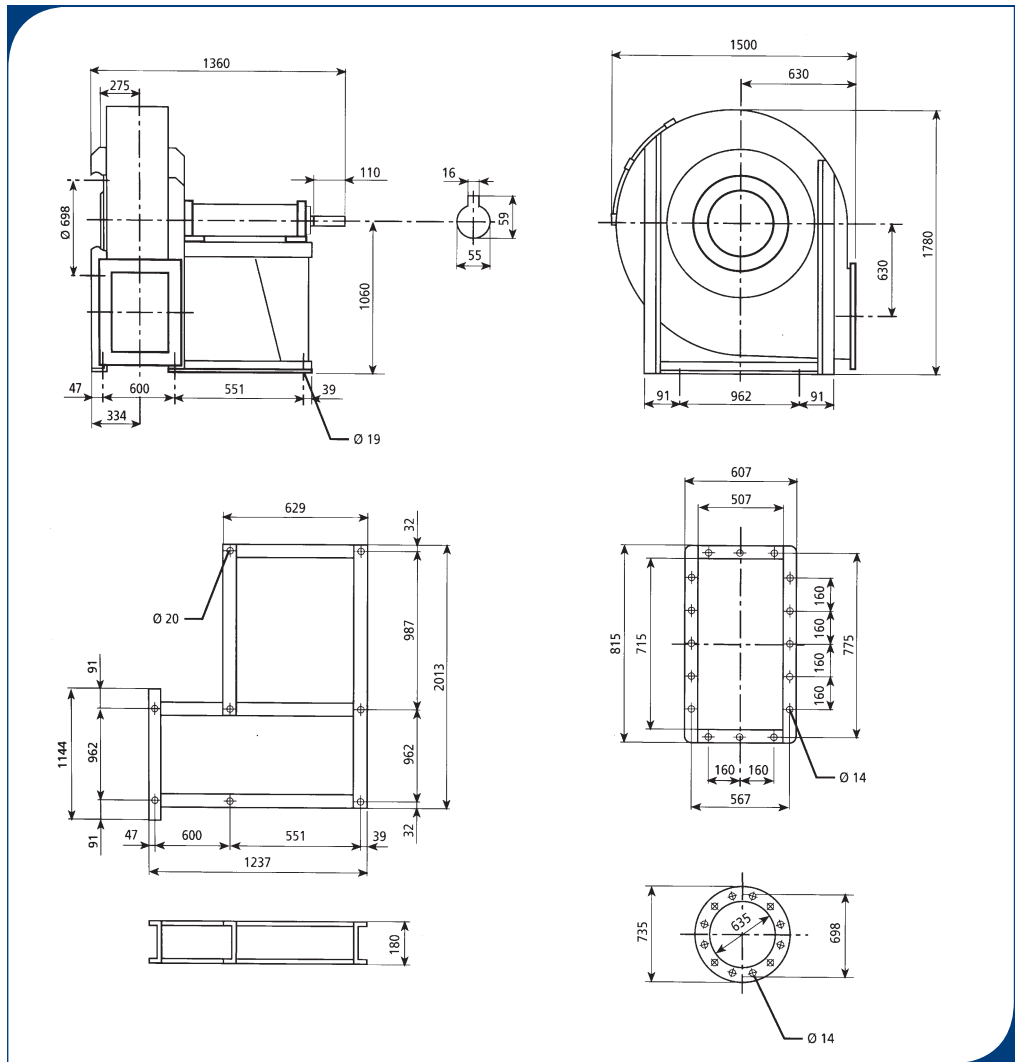

Peso ventilatore in kgf 410
Weight of ventilator in kgf 410

PD² = 34 kgf m²
GD² = 34 kgf m²

Massima velocità di rotazione
Maximum rotation speed

<100°C = 1600
100÷200°C = 1400
200÷300°C = 1250

Tolleranza sulla rumorosità + 3 dB(A)
Noise tolerance + 3 dB(A)

Tolleranza sulla potenza assorbita ± 3%
Absorbed power tolerance ± 3%

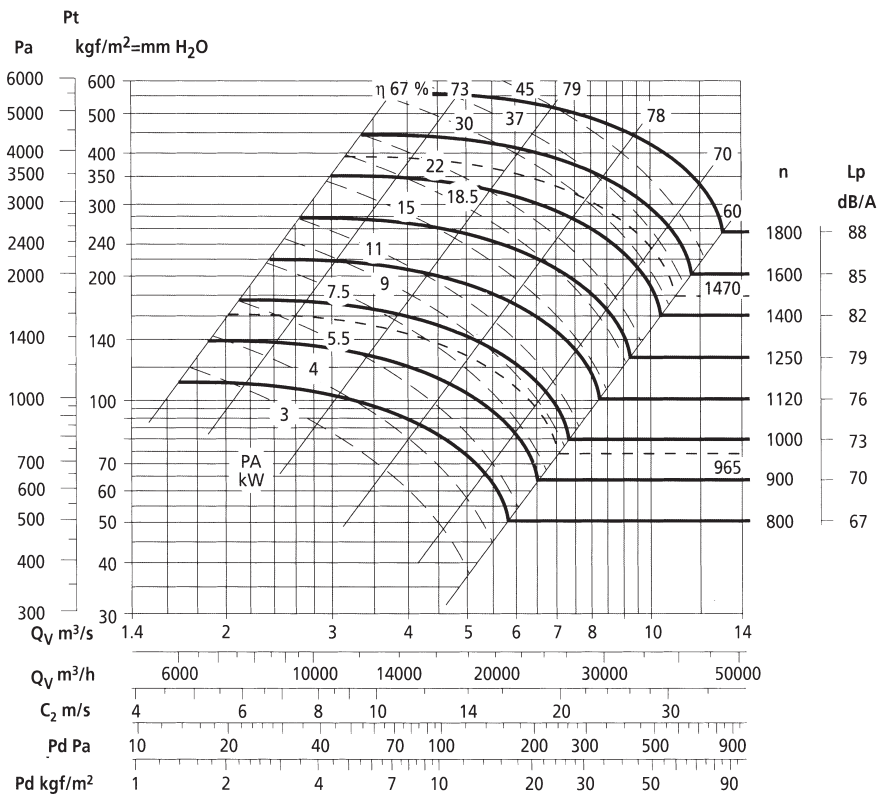

PRESTAZIONI VENTILATORI A TRASMISSIONE BELT BELT DRIVEN FANS PERFORMANCES



RM 1000T

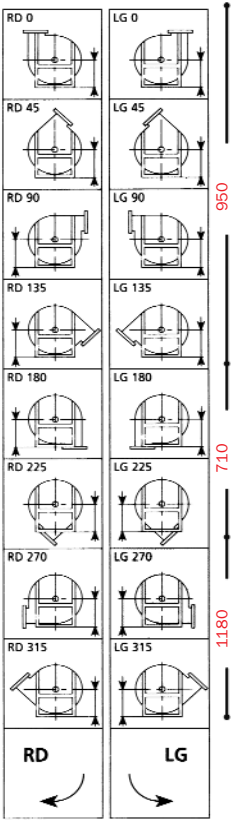

Il ventilatore **non** è orientabile
The fan is **not** revolvable

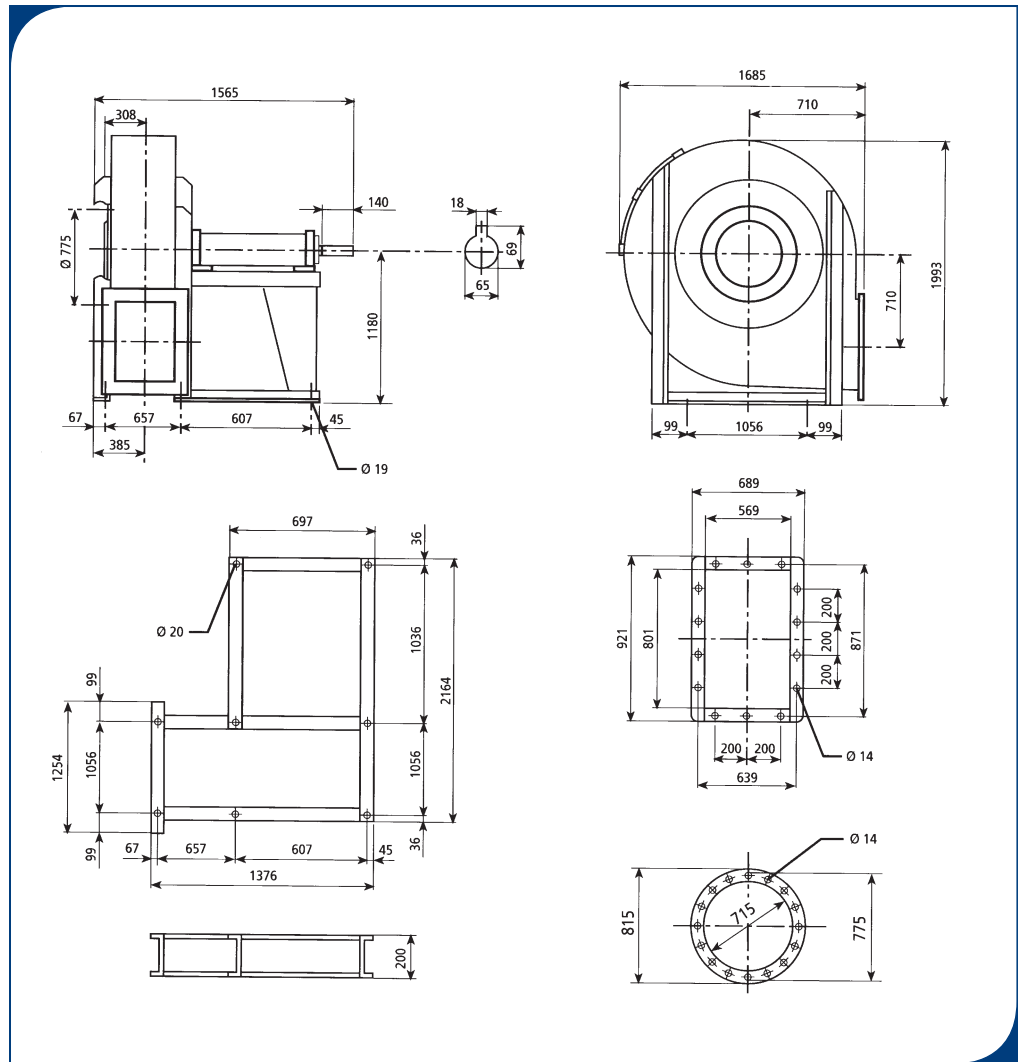

Peso ventilatore in kgf 530
Weight of ventilator in kgf 530

PD² = 53 kgf m²
GD² = 53 kgf m²

Massima velocità di rotazione
Maximum rotation speed

<100°C = 1400
100÷200°C = 1250
200÷300°C = 1120

Tolleranza sulla rumorosità + 3 dB(A)
Noise tolerance + 3 dB(A)

Tolleranza sulla potenza assorbita ± 3%
Absorbed power tolerance ± 3%

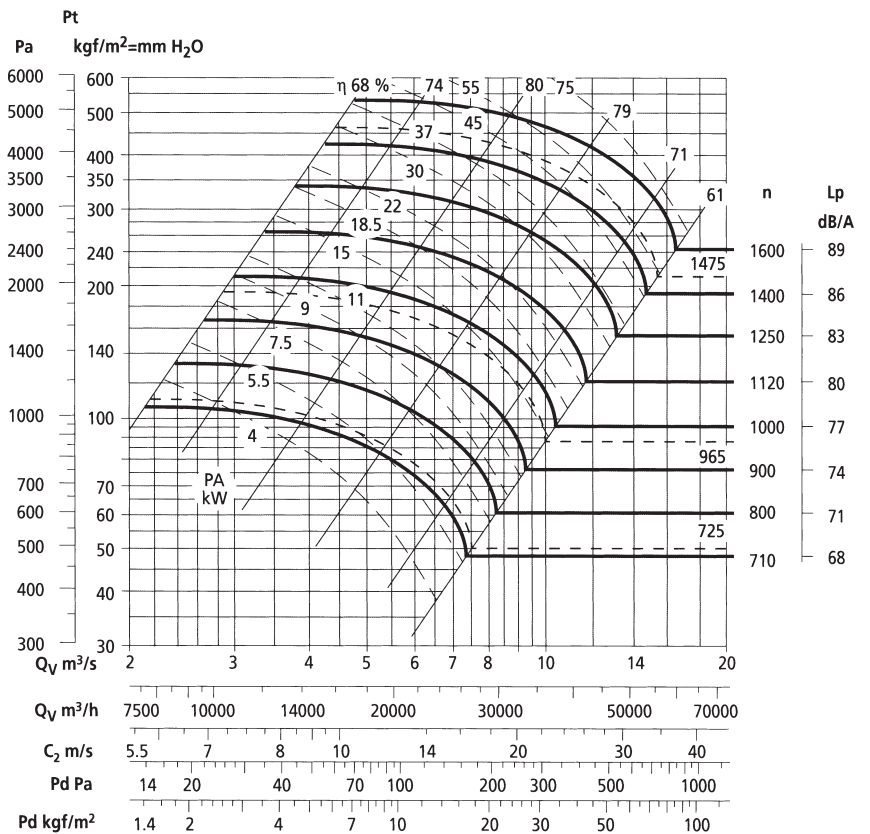



PRESTAZIONI VENTILATORI A TRASMISSIONE BELT DRIVEN FANS PERFORMANCES

RM 1120T

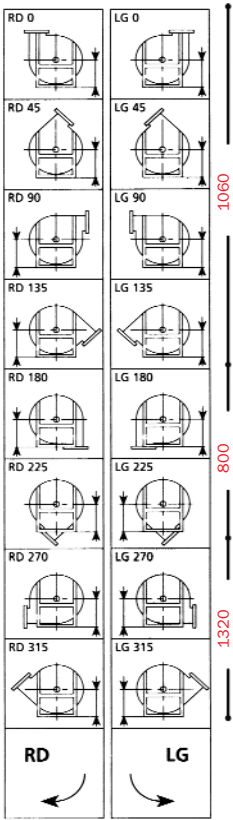

Il ventilatore **non** è orientabile
The fan is **not** revolvable

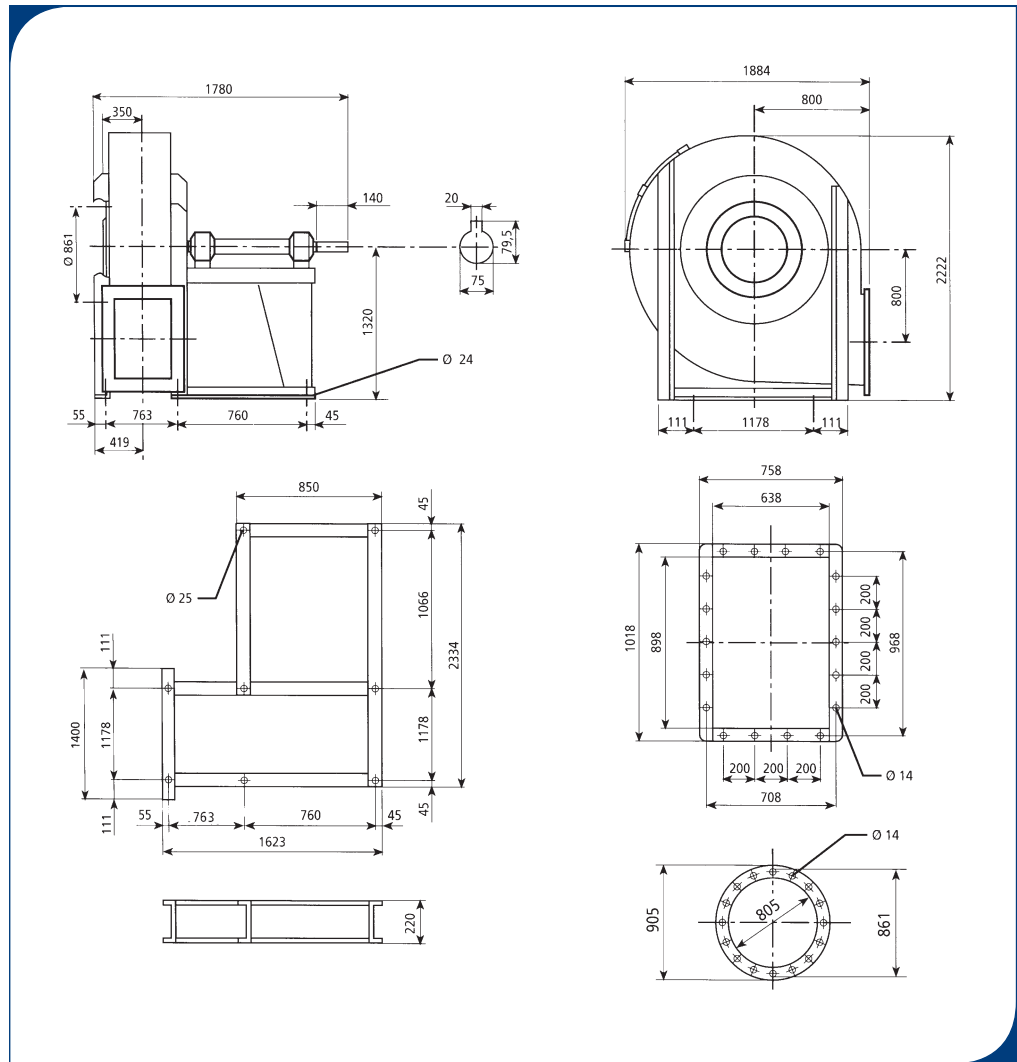

Peso ventilatore in kgf 860
Weight of ventilator in kgf 860

PD² = 118 kgf m²
GD² = 118 kgf m²

Massima velocità di rotazione
Maximum rotation speed

<100°C = 1250
100÷200°C = 1120
200÷300°C = 1000

Tolleranza sulla rumorosità + 3 dB(A)
Noise tolerance + 3 dB(A)

Tolleranza sulla potenza assorbita ± 3%
Absorbed power tolerance ± 3%

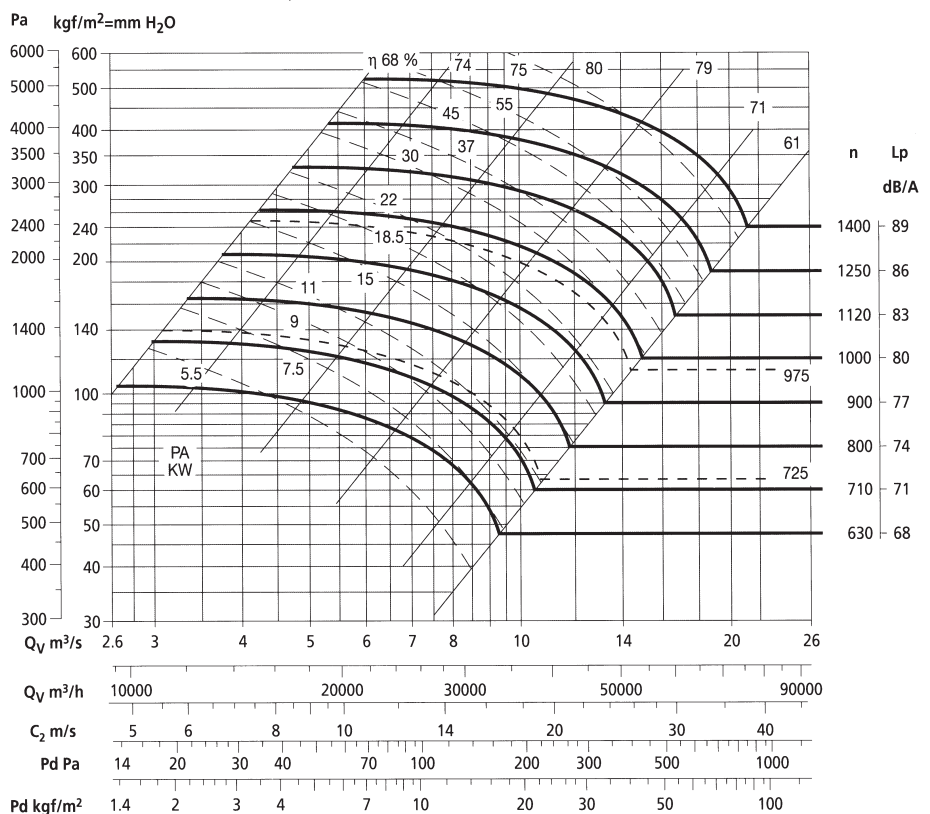

PRESTAZIONI VENTILATORI A TRASMISSIONE BELT BELT DRIVEN FANS PERFORMANCES



RM 1250T

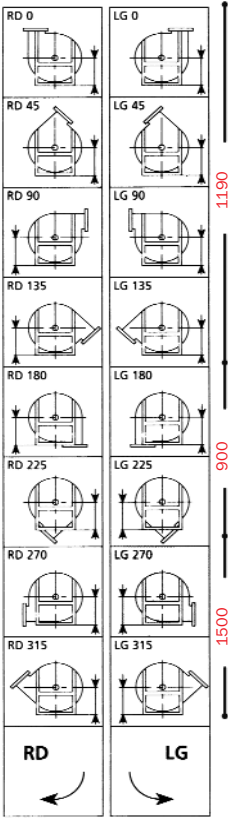

Il ventilatore **non** è orientabile
The fan is **not** revolvable

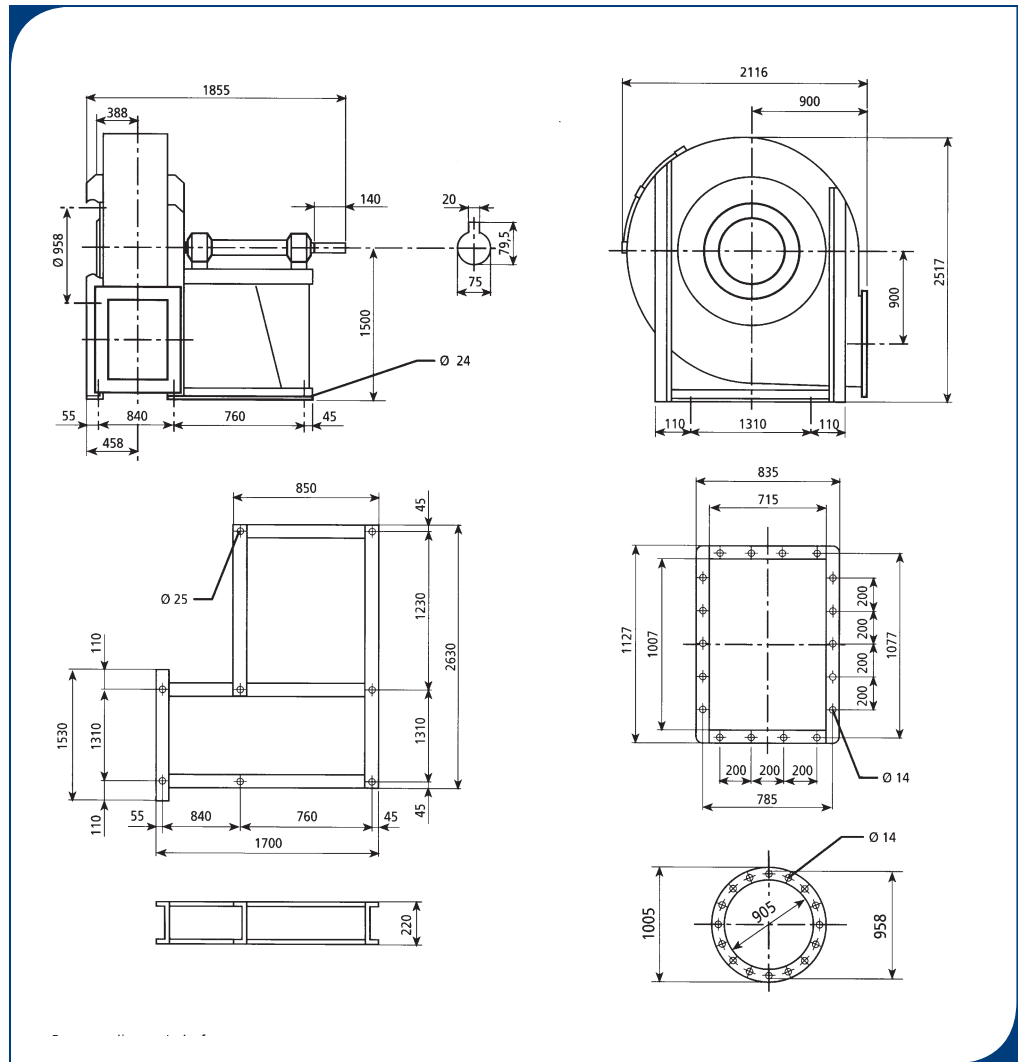

Peso ventilatore in kgf 1095
Weight of ventilator in kgf 1095

PD² = 190 kgf m²
GD² = 190 kgf m²

Massima velocità di rotazione
Maximum rotation speed

<100°C = 1120
100÷200°C = 1000
200÷300°C = 900

Tolleranza sulla rumorosità + 3 dB(A)
Noise tolerance + 3 dB(A)

Tolleranza sulla potenza assorbita ± 3%
Absorbed power tolerance ± 3%

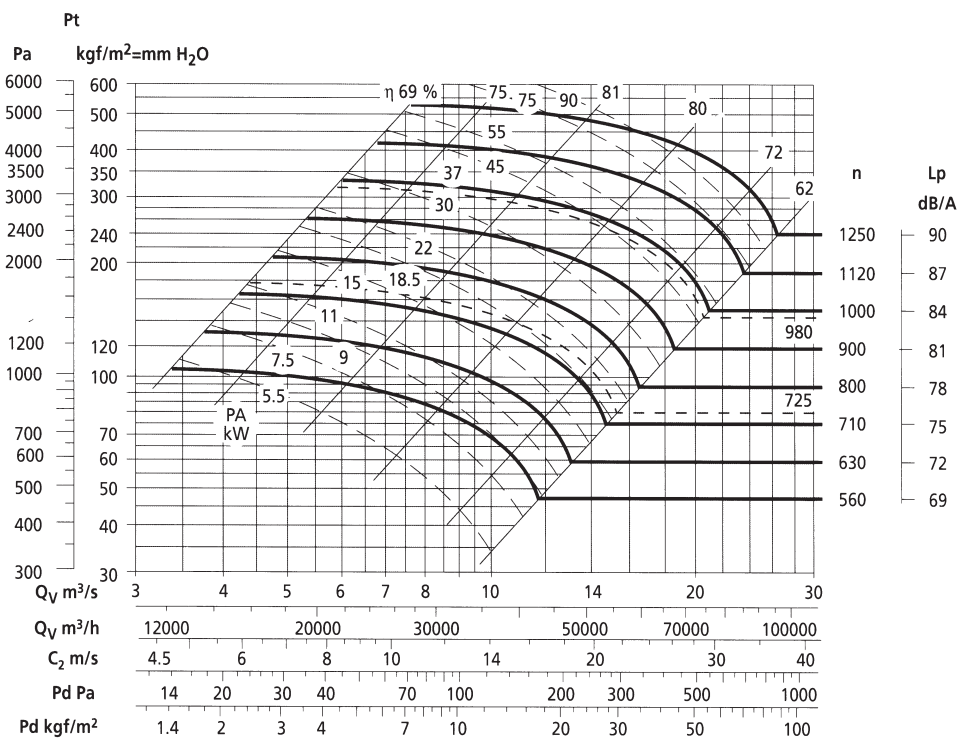

PRESTAZIONI VENTILATORI A TRASMISSIONE BELT BELT DRIVEN FANS PERFORMANCES



RM 1600T

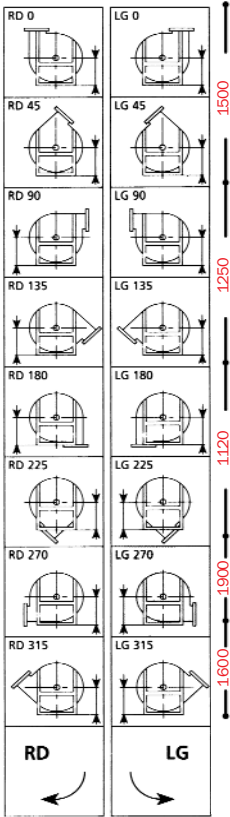

Il ventilatore **non** è orientabile
The fan is **not** revolvable

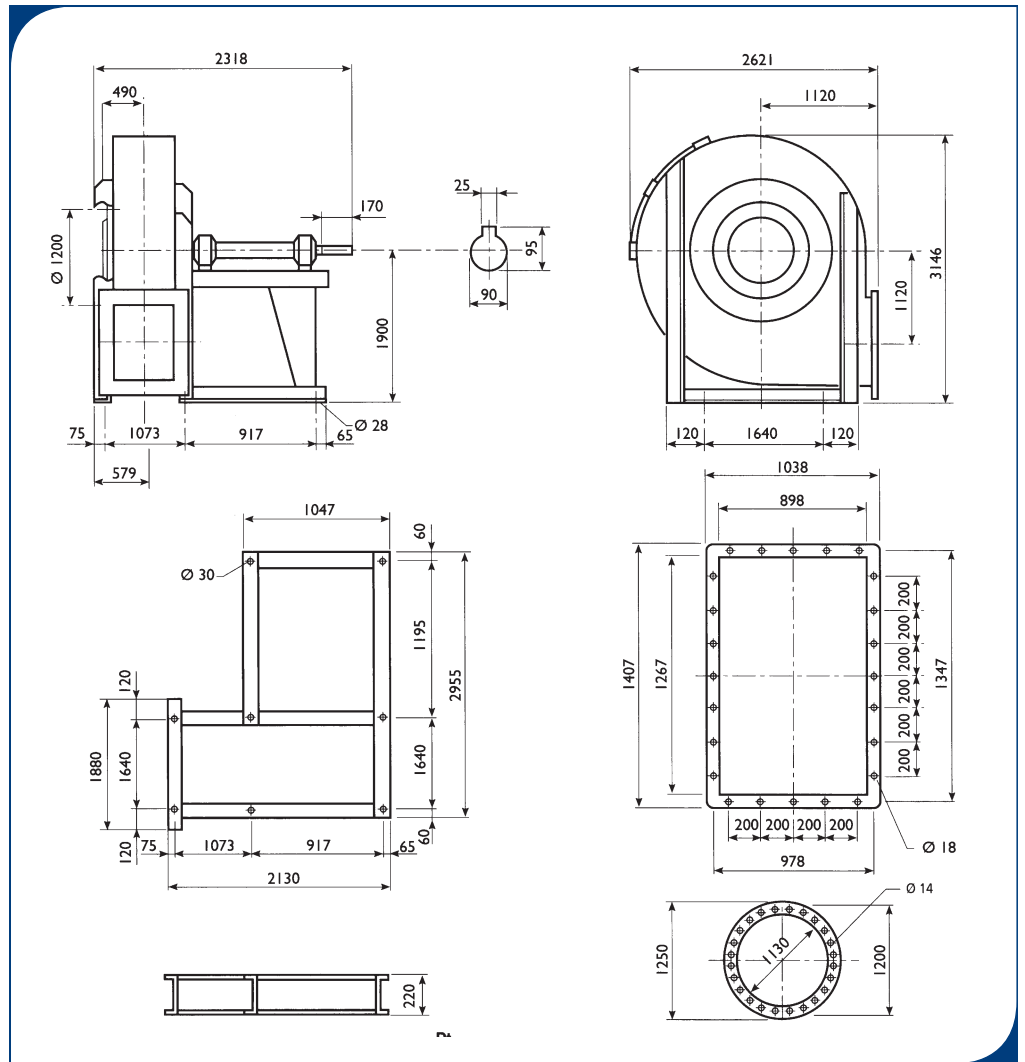

Peso ventilatore in kgf 1980
Weight of ventilator in kgf 1980

PD² = 530 kgf m²
GD² = 530 kgf m²

Massima velocità di rotazione
Maximum rotation speed

<100°C = 900
100÷200°C = 800
200÷300°C = 710

Tolleranza sulla rumorosità + 3 dB(A)
Noise tolerance + 3 dB(A)

Tolleranza sulla potenza assorbita ± 3%
Absorbed power tolerance ± 3%

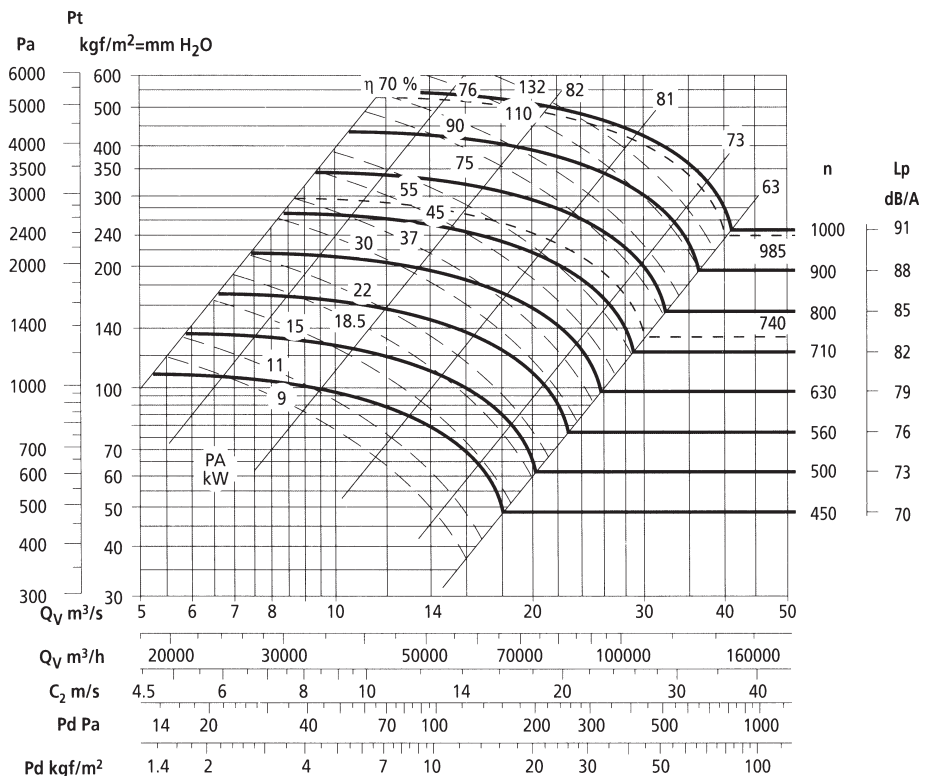

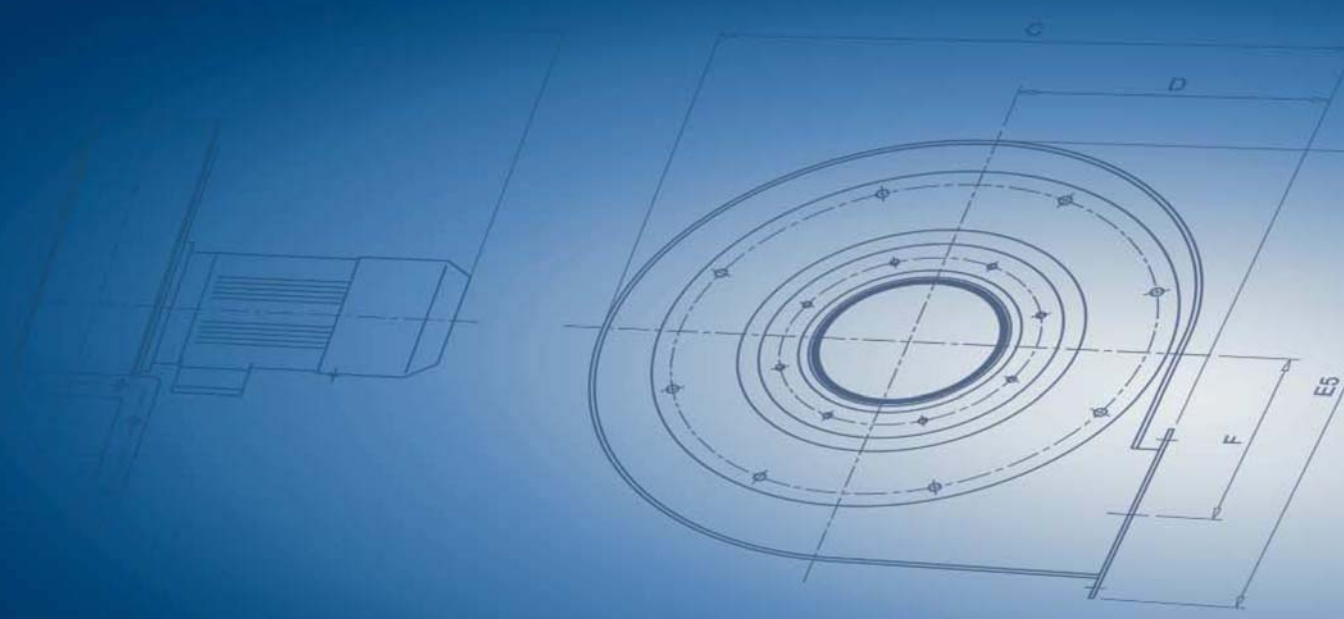

ACF Ventilatoren GmbH | Elf Stücken 21 | 49324 Melle | Tel.: +49(0)5422-9895-0 | Fax +49(0)5422-9895-15
www.acf-ventilatoren.de | info@acf-ventilatoren.de